

**SUN2000-(2KTL-5KTL)-L0**

# **User Manual**

**Issue**      02  
**Date**        2019-07-04

**HUAWEI TECHNOLOGIES CO., LTD.**



**Copyright © Huawei Technologies Co., Ltd. 2019. All rights reserved.**

No part of this document may be reproduced or transmitted in any form or by any means without prior written consent of Huawei Technologies Co., Ltd.

## **Trademarks and Permissions**



HUAWEI and other Huawei trademarks are trademarks of Huawei Technologies Co., Ltd.

All other trademarks and trade names mentioned in this document are the property of their respective holders.

## **Notice**

The purchased products, services and features are stipulated by the contract made between Huawei and the customer. All or part of the products, services and features described in this document may not be within the purchase scope or the usage scope. Unless otherwise specified in the contract, all statements, information, and recommendations in this document are provided "AS IS" without warranties, guarantees or representations of any kind, either express or implied.

The information in this document is subject to change without notice. Every effort has been made in the preparation of this document to ensure accuracy of the contents, but all statements, information, and recommendations in this document do not constitute a warranty of any kind, express or implied.

## **Huawei Technologies Co., Ltd.**

Address: Huawei Industrial Base  
Bantian, Longgang  
Shenzhen 518129  
People's Republic of China

Website: <http://e.huawei.com>

# About This Document

## Purpose

This document describes the SUN2000-(2KTL-5KTL) -L0 in terms of its installation, electrical connections, commissioning, maintenance, and troubleshooting. SUN2000-(2KTL-5KTL)-L0 is abbreviated as SUN2000. Before installing and operating the SUN2000, ensure that you are familiar with the features, functions, and safety precautions provided in this document.





## Intended Audience


This document is intended for upgrade personnel. Upgrade personnel must:

- Be familiar with the product networking and related NEs' versions.
- Have device maintenance experience and be familiar with device operation and maintenance.

## Symbol Conventions

The symbols that may be found in this document are defined as follows.

Symbol	Description
	Indicates an imminently hazardous situation which, if not avoided, will result in death or serious injury.
	Indicates a potentially hazardous situation which, if not avoided, could result in death or serious injury.
	Indicates a potentially hazardous situation which, if not avoided, may result in minor or moderate injury.
	Indicates a potentially hazardous situation which, if not avoided, could result in equipment damage, data loss, performance deterioration, or unanticipated results. NOTICE is used to address practices not related to personal injury.

Symbol	Description
 <b>NOTE</b>	Calls attention to important information, best practices and tips.  NOTE is used to address information not related to personal injury, equipment damage, and environment deterioration.

## Change History

Changes between document issues are cumulative. The latest document issue contains all updates made in previous issues.

### Issue 02 (2019-07-04)

- Delete the CHINT-DDSU666 Smart Power Sensor in [5.1 Preparing Cables](#).
- Added [6.3 Commissioning](#)
- Added [6.4 Grid-tied Point Control](#)
- Updated [9 Technical Specifications](#).

### Issue 01 (2018-08-30)

This issue is used for first office application (FOA).

---

# Contents

---

<b>About This Document</b> .....	<b>ii</b>
<b>1 Safety Precautions</b> .....	<b>1</b>
<b>2 Product Overview</b> .....	<b>5</b>
2.1 Product Introduction .....	5
2.2 Appearance .....	7
2.3 Label Descriptions .....	12
2.4 Working Principles.....	15
<b>3 Storage</b> .....	<b>17</b>
<b>4 System Installation</b> .....	<b>18</b>
4.1 Checking Before Installation .....	18
4.2 Tools and Instruments .....	19
4.3 Determining the Installation Position .....	20
4.4 Installing the Mounting Bracket .....	24
4.4.1 Wall-Mounted Installation .....	25
4.4.2 Support-mounted Installation .....	27
4.5 Installing the SUN2000 .....	29
4.6 (Optional) Installing the WiFi Antenna.....	33
4.7 (Optional) Installing the 4G Smart Dongle.....	34
<b>5 Electrical Connections</b> .....	<b>36</b>
5.1 Preparing Cables.....	37
5.2 Installing the PE Cable .....	40
5.3 Installing the AC Output Power Cable.....	42
5.4 Installing the DC Input Power Cable .....	46
5.5 Installing the Signal Cable.....	52
<b>6 System Commissioning</b> .....	<b>56</b>
6.1 Checking Before Power-On.....	56
6.2 Powering On the System.....	57
6.3 Commissioning .....	58
6.3.1 Scenario 1: Commissioning Through Setup Wizard .....	58
6.3.2 Scenario 2: Device Commissioning .....	61

---

6.4 Grid-tied Point Control .....	64
6.5 Powering Off the System .....	65
<b>7 System Maintenance.....</b>	<b>66</b>
7.1 Routine Maintenance .....	66
7.2 Troubleshooting .....	67
<b>8 Handling the SUN2000 .....</b>	<b>73</b>
8.1 Removing the SUN2000.....	73
8.2 Packing the SUN2000.....	73
8.3 Disposing of the SUN2000 .....	73
<b>9 Technical Specifications .....</b>	<b>74</b>
<b>A Grid Codes.....</b>	<b>78</b>
<b>B Acronyms and Abbreviations .....</b>	<b>79</b>

---

# 1 Safety Precautions

---

## General Safety

---

### NOTICE

- Before performing operations, read through this manual and follow all the precautions to prevent accidents. The "DANGER," "WARNING," "CAUTION," and "NOTICE" statements in this document do not represent all the safety instructions. They are only supplements to the safety instructions.
- Only certified electricians are allowed to install, connect cables for, commission, maintain, and troubleshoot Huawei products, and they must understand basic safety precautions to avoid hazards.

---

When operating Huawei equipment, in addition to following the general precautions in this document, follow the specific safety instructions given by Huawei. Huawei will not be liable for any consequence caused by the violation of the safety operation regulations and design, production, and usage standards.

## Disclaimer

Huawei shall not be liable for any consequence caused by any of the following events:

- Damage during the transportation by the customer
- Storage conditions that do not meet the requirements specified in this document
- Incorrect storage, installation, or use
- Installation or use by unqualified personnel
- Failure to comply with the operation instructions and safety precautions in this document
- Operation in extreme environments which are not covered in this document
- Operation beyond specified ranges
- Unauthorized modifications to the product or software code or removal of the product
- Device damage due to force majeure (such as earthquakes, fire, and storms)
- Warranty expiration without extension of the warranty service
- Installation or use in environments which are not specified in related international standards

## Personnel Requirements

Only certified electricians are allowed to install, connect cables for, commission, maintain, troubleshoot, and replace the SUN2000. They should:

- Receive professional training.
- Read through this document and follow all the precautions.
- Be familiar with the safety specifications about the electrical system.
- Understand the composition and working principles of the grid-tied PV system and local regulations.
- Wear proper personal protective equipment (PPE).

## Protecting Labels

- Do not scrawl or damage any labels on the SUN2000 enclosure because these labels contain important information about safe operation.
- Do not scrawl or damage the nameplate on the SUN2000 enclosure. This nameplate contains important product information.

## Installation



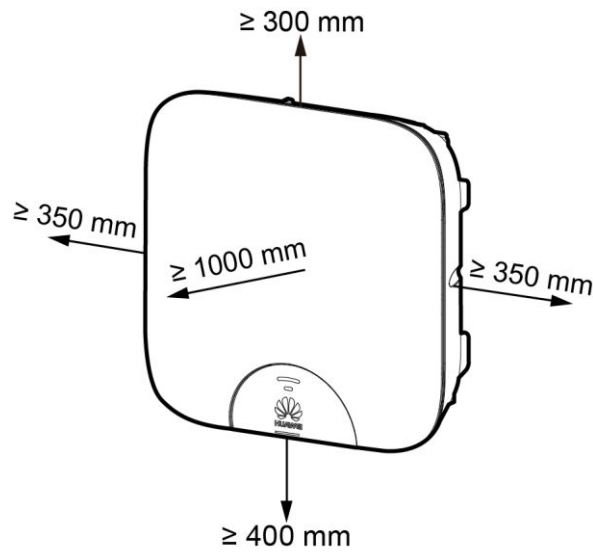
Never power on the SUN2000 during installation.

---

- Ensure that the SUN2000 is not connected to a power supply or powered on before installation is complete.
- To allow proper heat dissipation and installation, maintain appropriate clearances between the SUN2000 and other objects, as shown in [Figure 1-1](#). If you have any questions about the clearances, consult technical support engineers.



**Figure 1-1** Installation clearances



- Ensure that the SUN2000 is installed in a well-ventilated environment.
- Ensure that the SUN2000 heat sinks are free from blockage.
- Do not open the front panel of the SUN2000.
- Do not remove the terminals and ports at the bottom of the SUN2000.

## Electrical Connections

### **⚠ DANGER**

Before connecting cables, ensure that the SUN2000 is secured in position and not damaged in any way. Otherwise, electric shocks or fire may occur.

- Ensure that all electrical connections comply with the local electrical standards.
- Obtain approval from the local utility company before using the SUN2000 to generate electricity in grid-tied mode.
- Ensure that the cables used in a grid-tied PV system are properly connected and insulated and meet all specification requirements.

## Operation

### **⚠ DANGER**

The high voltage generated by the SUN2000 during operation may cause an electric shock, which can result in serious property damage, serious injury, or death. Strictly comply with the safety precautions in this document and associated documents when operating the SUN2000.

- When the SUN2000 is powered on for the first time, only certified electricians are allowed to perform quick setting. Incorrect settings may affect the normal SUN2000 operation and cause the SUN2000 to not comply with the country certification.
- When the SUN2000 is operating, do not disconnect under load.
- Do not touch an energized SUN2000 because the heat sink reaches a high temperature.
- Follow local laws and regulations when operating the equipment.

## Maintenance and Replacement



The high voltage generated by the SUN2000 during operation may cause an electric shock, which can result in serious property damage, serious injury, or death. Prior to maintenance, power off the SUN2000 and strictly comply with the safety precautions in this document and associated documents to operate the SUN2000.

- Before performing maintenance on the SUN2000, ensure that you have sufficient knowledge of this document, and proper tools and testing equipment.
- Before performing maintenance tasks, power off the SUN2000 and wait at least 5 minutes.
- Temporary warning signs or fences must be placed to prevent unauthorized people from entering the site.
- If the SUN2000 is faulty, contact your supplier.
- The SUN2000 can be powered on only after all faults are rectified. Failing to do so may escalate faults or damage the device.
- Observe ESD precautions and wear ESD gloves during maintenance.

# 2 Product Overview

## 2.1 Product Introduction

### Function

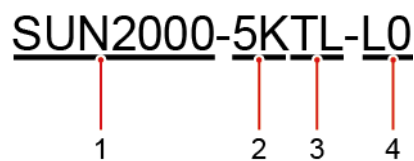
The SUN2000 is a single-phase grid-tied PV string inverter that converts the DC power generated by PV strings into AC power and feeds the electricity into the power grid.

### Models

This document involves the following product models:

- SUN2000-2KTL-L0
- SUN2000-3KTL-L0
- SUN2000-4KTL-L0
- SUN2000-5KTL-L0

**Figure 2-1** Designation explanation of the SUN2000-5KTL-L0



**Table 2-1** Designation explanation

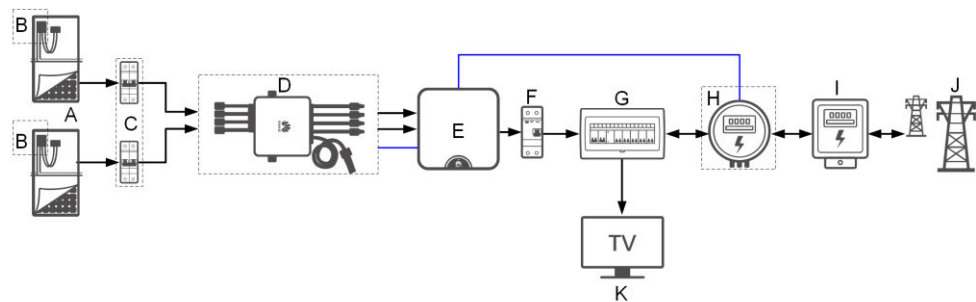
No.	Meaning	Description
1	Series name	SUN2000: single-phase grid-tied PV string inverter
2	Power level	<ul style="list-style-type: none"><li>• 2K: The power level is 2K.</li><li>• 3K: The power level is 3K.</li><li>• 4K: The power level is 4K.</li><li>• 5K: The power level is 5K.</li></ul>

No.	Meaning	Description
3	Topology	TL: transformerless
4	Design code	L0: residential

## Networking Application

The SUN2000 applies to a residential rooftop grid-tied system. Typically, a grid-tied system consists of the PV string, grid-tied inverter, AC switch, and power distribution unit.

**Figure 2-2** Network diagram (dashed boxes indicate optional components)



### NOTE

— indicates a power cable,  
— indicates a signal cable.



→ indicates the power flow direction,



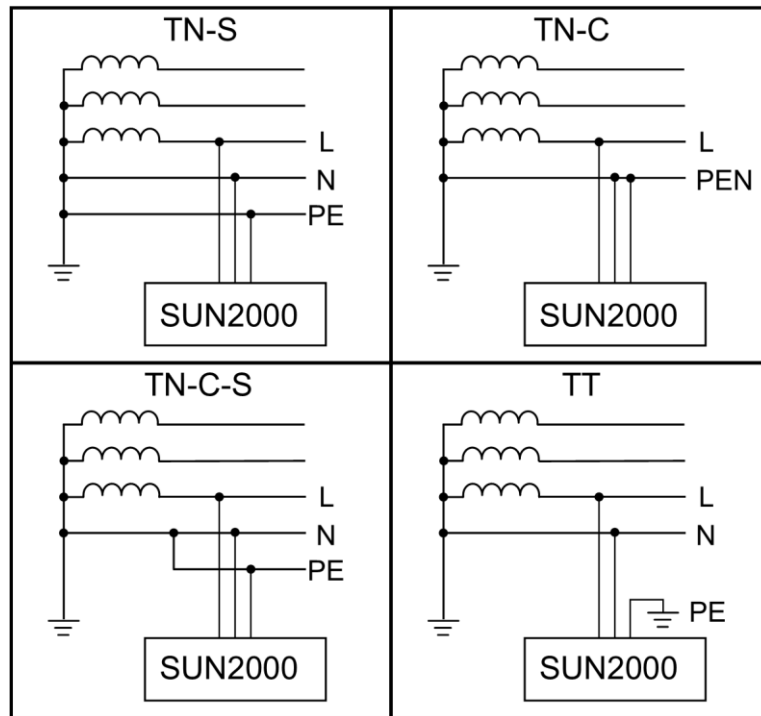
— indicates a signal cable.

- |                             |                        |                 |
|-----------------------------|------------------------|-----------------|
| (A) PV string               | (B) Smart PV Optimizer | (C) DC switch   |
| (D) Smart PV Safety Box     | (E) SUN2000            | (F) AC switch   |
| (G) Power distribution unit | (H) Smart Power Sensor | (I) Power meter |
| (J) Power grid              | (K) Home load          |                 |

## Supported Power Grid

The power grids supported by the SUN2000 include TN-S, TN-C, TN-C-S, and TT. In a TT power grid, the N-PE voltage should be lower than 30 V.

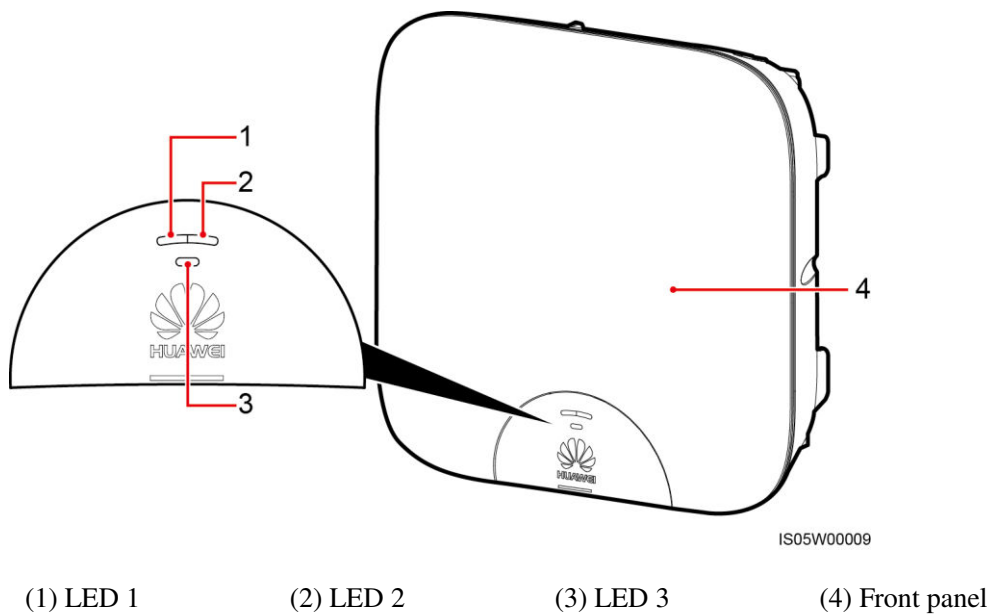
**Figure 2-3** Power grid types



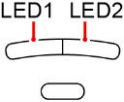
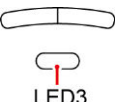
## 2.2 Appearance

### Front View

**Figure 2-4** Front view

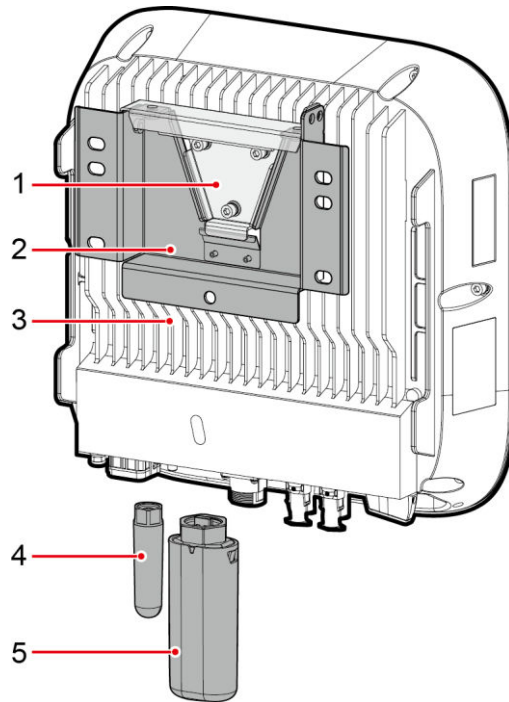


**Table 2-2** LED description

Type	Status		Meaning
Running indication 	<b>LED 1</b>	<b>LED 2</b>	N/A
	Steady green	Steady green	The SUN2000 is exporting power to the power grid.
	Blinking green at long intervals (on for 1s and then off for 1s)	Off	The DC is on and the AC is off.
	Off	Blinking green at long intervals (on for 1s and then off for 1s)	The DC is off and the AC is on.
	Blinking green at long intervals (on for 1s and then off for 1s)	Blinking green at long intervals (on for 1s and then off for 1s)	Both the DC and AC are on, and the SUN2000 is not exporting power to the power grid.
	Off	Off	Both the DC and AC are off, or the SUN2000 is in low power consumption mode which means that the monitoring system of the SUN2000 hibernates.
	Steady red	Steady red	The SUN2000 is faulty
Communication indication 	<b>LED 3</b>		N/A
	Blinking green at short intervals (on for 0.2s and then off for 0.2s)		Communicating (Communicating refers to that the communication with the upper-level management unit is in progress. However, if a mobile phone accesses the SUN2000, the LED indicates the "mobile phone access status: blinking green at long intervals" first.)
	Blinking green at long intervals (on for 1s and then off for 1s)		The mobile phone has connected to the SUN2000.
Off		No communication	

## Rear view

Figure 2-5 Rear view



IS05W00046

- (1) Mounting plate                      (2) Mounting bracket                      (3) Heat sink  
(4) WiFi antenna (optional)        (5) 4G Smart Dongle (optional)

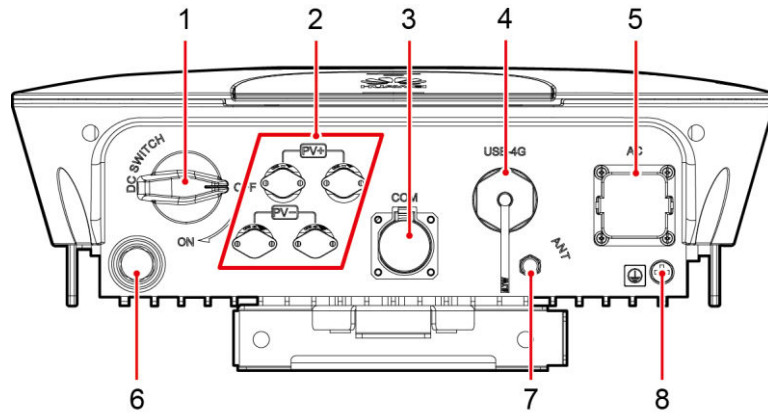


### NOTE

The Smart Dongle and WiFi antenna cannot be used at the same time.

## Bottom View

Figure 2-6 Bottom view



IS05W00013

No.	Component	Silk Screen
1	DC switch	DC SWITCH
2	DC input terminals	PV+/PV-
3	COM port	COM
4	USB-4G port	USB-4G
5	AC output port	AC
6	Ventilation valve	N/A
7	Antenna port	ANT
8	Ground point	N/A



## Dimensions

Figure 2-7 SUN2000 dimensions

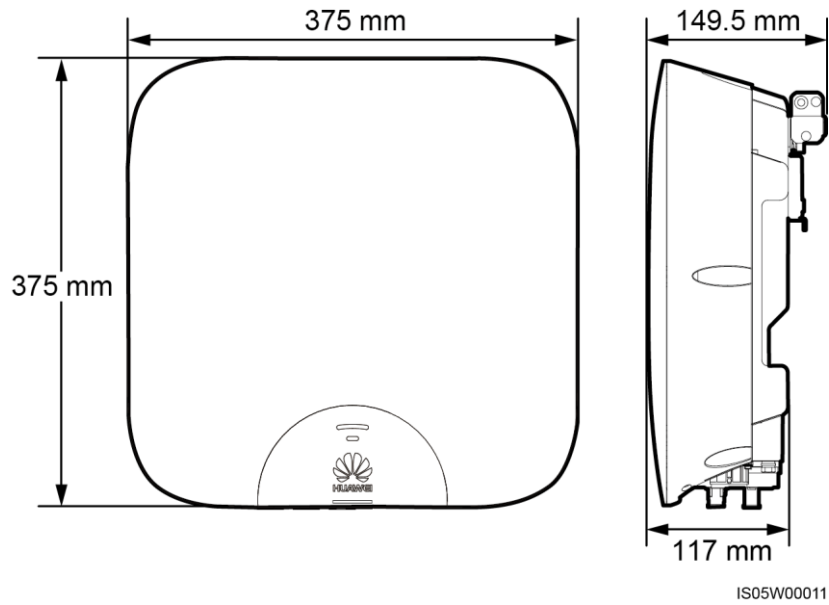
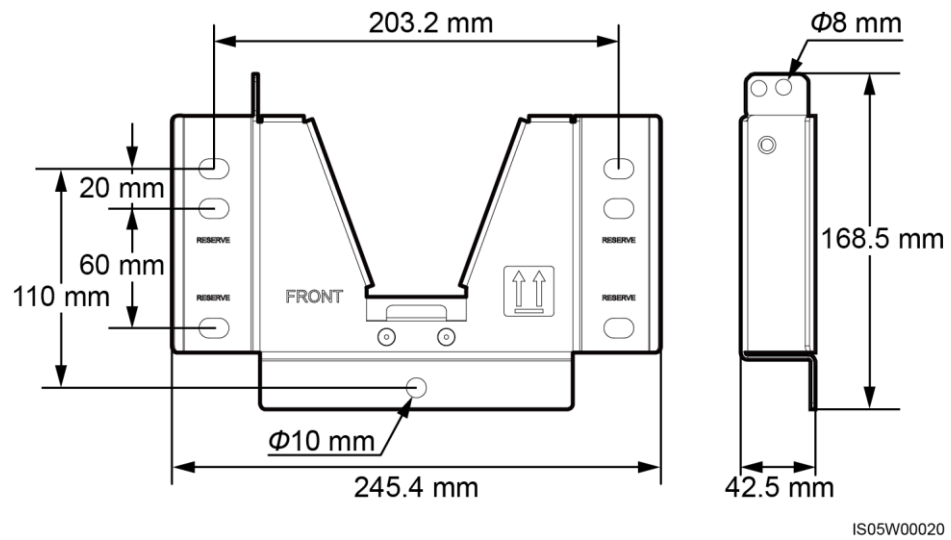






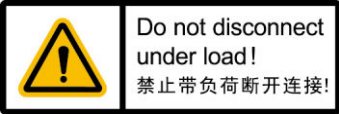
Figure 2-8 Mounting bracket dimensions



## 2.3 Label Descriptions

### Labels

Table 2-3 Label description

Symbol	Name	Meaning
	Burn warning	Do not touch a running SUN2000 because the shell is hot when the SUN2000 is running.
	Delay discharge	<ul style="list-style-type: none"> <li>High voltage exists after the SUN2000 is powered on. Only qualified and trained electrical technicians are allowed to perform operations on the SUN2000.</li> <li>Residual voltage exists after the SUN2000 is powered off. It takes 5 minutes for the SUN2000 to discharge to the safe voltage.</li> </ul>
	Refer to documentation	Reminds operators to refer to the documents supplied with the SUN2000.
	Grounding	Indicates the position for connecting the protective earthing (PE) cable.
	Operation warning	Do not remove the connector or antenna when the SUN2000 is running.

Symbol	Name	Meaning																																		
<table border="1"> <thead> <tr> <th colspan="3">运行指示 Running indication</th> </tr> <tr> <th>LED1</th> <th>LED2</th> <th>指示定义 Meaning</th> </tr> </thead> <tbody> <tr> <td>绿色常亮 Steady green</td> <td>绿色常亮 Steady green</td> <td>并网 Exporting power to the power grid</td> </tr> <tr> <td>绿色慢闪 Blinking green at long intervals</td> <td>灭 Off</td> <td>直流上电且交流未上电 DC on and AC off</td> </tr> <tr> <td>灭 Off</td> <td>绿色慢闪 Blinking green at long intervals</td> <td>直流未上电且交流上电 DC off and AC on</td> </tr> <tr> <td>绿色慢闪 Blinking green at long intervals</td> <td>绿色慢闪 Blinking green at long intervals</td> <td>直流上电且交流上电(未并网) DC on and AC on (no power to the power grid)</td> </tr> <tr> <td>灭 Off</td> <td>灭 Off</td> <td>直流未上电且交流未上电或进入低功耗模式 Either DC off and AC off or in low power consumption mode</td> </tr> <tr> <td>红色常亮 Steady red</td> <td>红色常亮 Steady red</td> <td>故障 Fault</td> </tr> </tbody> </table> <table border="1"> <thead> <tr> <th colspan="2">通讯指示 Communication indication</th> </tr> <tr> <th>LED3</th> <th>指示定义 Meaning</th> </tr> </thead> <tbody> <tr> <td>绿色快闪 Blinking green at short intervals</td> <td>通讯中 Communicating</td> </tr> <tr> <td>绿色慢闪 Blinking green at long intervals</td> <td>手机接入 Connected to the mobile phone</td> </tr> <tr> <td>灭 Off</td> <td>其他 Others</td> </tr> </tbody> </table> 	运行指示 Running indication			LED1	LED2	指示定义 Meaning	绿色常亮 Steady green	绿色常亮 Steady green	并网 Exporting power to the power grid	绿色慢闪 Blinking green at long intervals	灭 Off	直流上电且交流未上电 DC on and AC off	灭 Off	绿色慢闪 Blinking green at long intervals	直流未上电且交流上电 DC off and AC on	绿色慢闪 Blinking green at long intervals	绿色慢闪 Blinking green at long intervals	直流上电且交流上电(未并网) DC on and AC on (no power to the power grid)	灭 Off	灭 Off	直流未上电且交流未上电或进入低功耗模式 Either DC off and AC off or in low power consumption mode	红色常亮 Steady red	红色常亮 Steady red	故障 Fault	通讯指示 Communication indication		LED3	指示定义 Meaning	绿色快闪 Blinking green at short intervals	通讯中 Communicating	绿色慢闪 Blinking green at long intervals	手机接入 Connected to the mobile phone	灭 Off	其他 Others	Indicator status description label	Describes the indicator status.
运行指示 Running indication																																				
LED1	LED2	指示定义 Meaning																																		
绿色常亮 Steady green	绿色常亮 Steady green	并网 Exporting power to the power grid																																		
绿色慢闪 Blinking green at long intervals	灭 Off	直流上电且交流未上电 DC on and AC off																																		
灭 Off	绿色慢闪 Blinking green at long intervals	直流未上电且交流上电 DC off and AC on																																		
绿色慢闪 Blinking green at long intervals	绿色慢闪 Blinking green at long intervals	直流上电且交流上电(未并网) DC on and AC on (no power to the power grid)																																		
灭 Off	灭 Off	直流未上电且交流未上电或进入低功耗模式 Either DC off and AC off or in low power consumption mode																																		
红色常亮 Steady red	红色常亮 Steady red	故障 Fault																																		
通讯指示 Communication indication																																				
LED3	指示定义 Meaning																																			
绿色快闪 Blinking green at short intervals	通讯中 Communicating																																			
绿色慢闪 Blinking green at long intervals	手机接入 Connected to the mobile phone																																			
灭 Off	其他 Others																																			
 SN: xxxxxxxxxxxxxxxxxxxxxx	SUN2000 serial number (SN) label	Indicates the SUN2000 SN.																																		
 MAC: xxxxxxxxxxxxxx	SUN2000 MAC address label	Indicates the MAC address.																																		
	QR code for SUN2000 WiFi connection	Scan the QR code to connect to Huawei SUN2000 WiFi network .																																		

**NOTE**

The labels are for reference only.

## Nameplate

Figure 2-9 Nameplate of the SUN2000-5KTL-L0



- (1) Trademark and product model
- (3) Compliance symbols

- (2) Important technical specifications
- (4) Company name and country of manufacture



### NOTE

The nameplate figure is for reference only.

Table 2-4 Compliance symbols

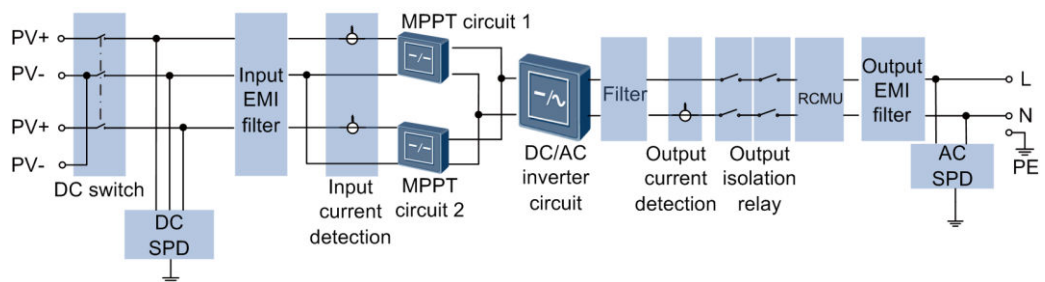
Symbol	Name	Meaning
	RCM certification mark	The SUN2000 complies with RCM certification standards.
	CE certification mark	The SUN2000 complies with Conformité Européenne (CE) certification standards.
	TÜVRheinland certification mark	The SUN2000 complies with TÜVRheinland certification standards.
	Environment friendly use period (EFUP) mark	The product does not pollute the environment during the specified period.
	EU waste electrical and electronic equipment (WEEE) mark	Do not dispose of the product as household garbage.

## 2.4 Working Principles

### Conceptual Diagram

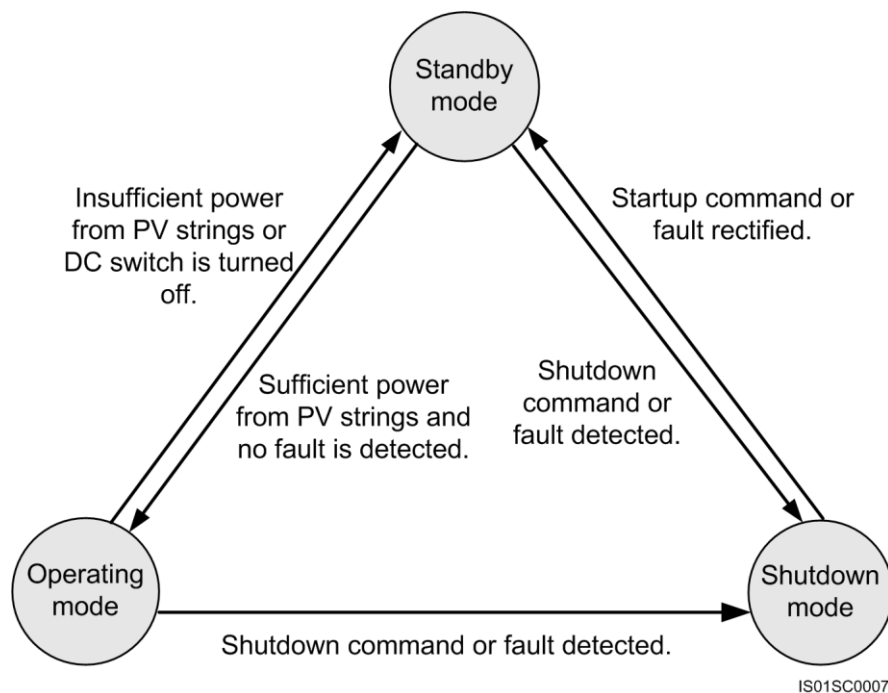
The SUN2000 receives two inputs from the two PV strings. Two MPPT circuits are configured inside the SUN2000. Each circuit tracks the maximum power point of one PV string respectively. The DC power is then converted into single-phase AC power through an inverter circuit. Surge protection is supported on both the DC and AC sides.

**Figure 2-10** Conceptual diagram



### Working Modes

**Figure 2-11** Working modes



**Table 2-5** Working mode description

<b>Working Mode</b>	<b>Description</b>
Standby	<p>The SUN2000 enters Standby mode when the external environment does not meet the requirements for starting the SUN2000. In Standby mode:</p> <ul style="list-style-type: none"><li>• The SUN2000 continuously checks its status and enters Operating mode once the operating requirements are met.</li><li>• The SUN2000 enters Shutdown mode after detecting a shutdown command or a fault after startup.</li></ul>
Operating	<p>In Operating mode:</p> <ul style="list-style-type: none"><li>• The SUN2000 converts DC power from PV strings into AC power and feeds the energy to the power grid.</li><li>• The SUN2000 tracks the maximum power point to maximize the PV string output.</li><li>• The SUN2000 enters Shutdown mode after detecting a fault or a shutdown command, and enters Standby mode after detecting that the PV string output power is not suitable for connecting to the power grid and producing power.</li></ul>
Shutdown	<ul style="list-style-type: none"><li>• In Standby or Operating mode, the SUN2000 enters Shutdown mode after detecting a fault or shutdown command.</li><li>• In Shutdown mode, the SUN2000 enters Standby mode after detecting a startup command or that the fault is rectified.</li></ul>

# 3 Storage

---

The following requirements should be met when the SUN2000 needs to be stored prior to installation:

- Do not unpack the SUN2000.
- Keep the storage temperature at  $-40^{\circ}\text{C}$  to  $+70^{\circ}\text{C}$  and the humidity at 5%–95% RH.
- The SUN2000 should be stored in a clean and dry place and be protected from dust and water vapor corrosion.
- A maximum of 10 SUN2000s can be stacked. To avoid personal injury or device damage, stack SUN2000s with caution to prevent them from falling over.
- Regular inspection is required during the storage. Replace the packing materials when necessary.
- After long-term storage, the SUN2000 needs to be inspected and tested by qualified persons before it is put into use.

# 4 System Installation

---

## 4.1 Checking Before Installation

### Outer Packing Materials

Before unpacking the SUN2000, check the outer packing materials for damage, such as holes and cracks, and check the SUN2000 model. If any damage is found or the SUN2000 model is not what you requested, do not unpack the product and contact your supplier as soon as possible.

---

**NOTICE**

You are advised to remove the packing materials no more than 24 hours before installing the SUN2000.

---

### Package Contents

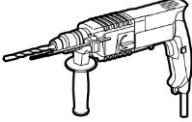
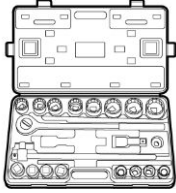

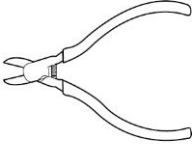
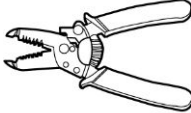
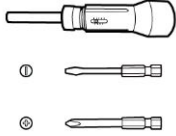



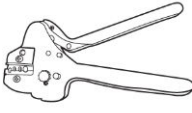





After unpacking the SUN2000, check that the contents are intact and complete. If any damage is found or any component is missing, contact your supplier.

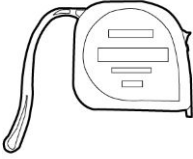
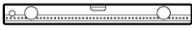
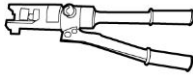
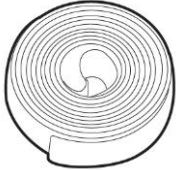





**NOTE**

For details about the number of contents, see the *Packing List* in the packing case.



## 4.2 Tools and Instruments

Category	Tools and Instruments		
Installation			
	Hammer drill (with a $\Phi 10$ mm drill bit)	Torque socket wrench (open end: 13 mm, applicable for M8 bolts; torque range: 0–15 N m)	Torque wrench (open end: 13 mm; torque range: 0–1.5 N m)
			
	Diagonal pliers	Wire stripper	Torque screwdriver (head: M4 or M6; torque range: 0–5 N m)
			
	Rubber mallet	Utility knife	Cable cutter
			
Crimping tool (model: UTXTC0005/H4TC0003; manufacturer: Amphenol)	Open-end wrench (model: H4TW0001; manufacturer: Amphenol)	Cable tie	
			
Vacuum cleaner	Multimeter (DC voltage measurement range $\geq 600$ V DC)	Marker	

Category	Tools and Instruments		
			
	Measuring tape	Bubble or digital level	Hydraulic pliers
			N/A
	Heat shrink tubing	Heat gun	N/A
PPE			
	Safety gloves	Safety goggles	Anti-dust respirator
		N/A	N/A
	Safety shoes	N/A	N/A

## 4.3 Determining the Installation Position

### Basic Requirements

- The SUN2000 is protected to IP65 and can be installed indoors or outdoors.
- Do not install the SUN2000 in a place where a person can easily touch it because its enclosure and heat sinks are extremely hot during operation.
- Do not install the SUN2000 in areas with flammable or explosive materials.
- Do not install the SUN2000 at a place within children's reach.
- Do not install the SUN2000 outdoors in salt areas because it will be corroded there and may cause fire. A salt area refers to the region within 500 meters from the coast or prone to sea breeze. The regions prone to sea breeze vary depending on weather conditions (such as typhoons and monsoons) or terrains (such as dams and hills).

## Installation Environment Requirements

- The SUN2000 must be installed in a well-ventilated environment to ensure good heat dissipation.
- When installed under direct sunlight, the power of the SUN2000 may be derated due to additional temperature rise.
- Install the SUN2000 in a sheltered place or install an awning over the SUN2000.

## Mounting Structure Requirements

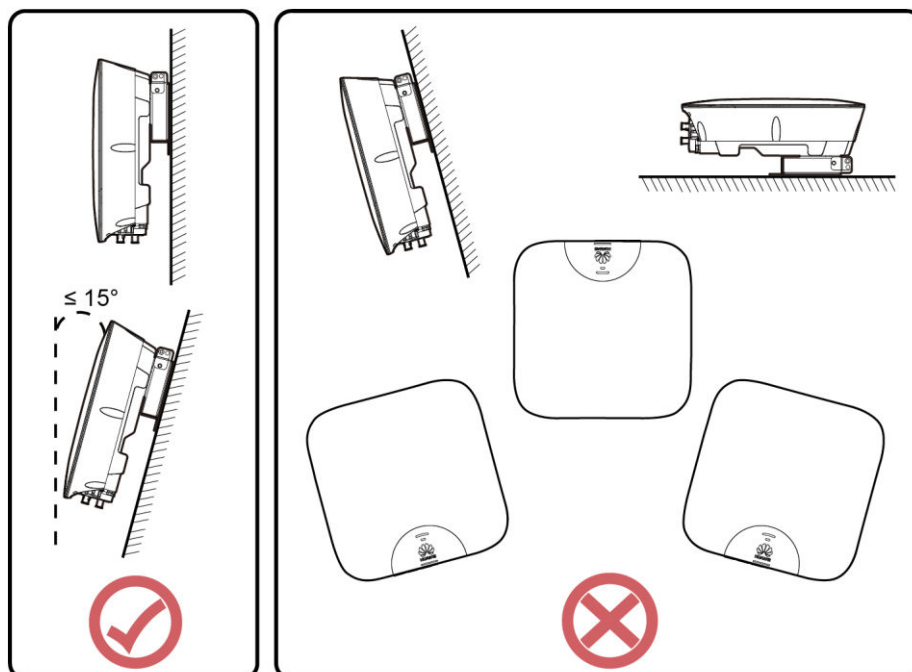
- The mounting structure where the SUN2000 is installed must be fireproof.
- Do not install the SUN2000 on flammable building materials.
- Ensure that the installation surface is solid enough to bear the weight load.
- In residential areas, do not install the SUN2000 on drywalls or walls made of similar materials which have a weak sound insulation performance because the noise generated by the SUN2000 is noticeable.

## Installation Angle Requirements

The SUN2000 can be wall-mounted or pole-mounted. The installation angle requirements are as follows:

- Install the SUN2000 vertically or at a maximum back tilted angle of 15 degrees to facilitate heat dissipation.
- Do not install the SUN2000 at forward tilted, excessively back tilted, side tilted, horizontal, or upside down positions.

**Figure 4-1** Installation angle

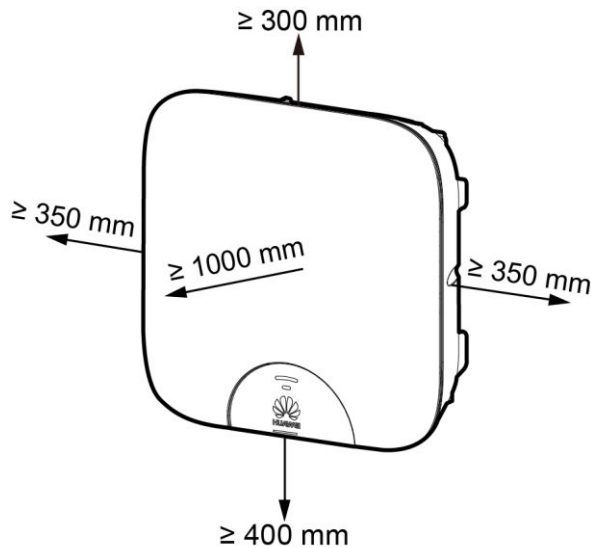


IS05W00014

## Installation Clearance Requirements

- Reserve enough clearance around the SUN2000 to ensure sufficient space for installation and heat dissipation.

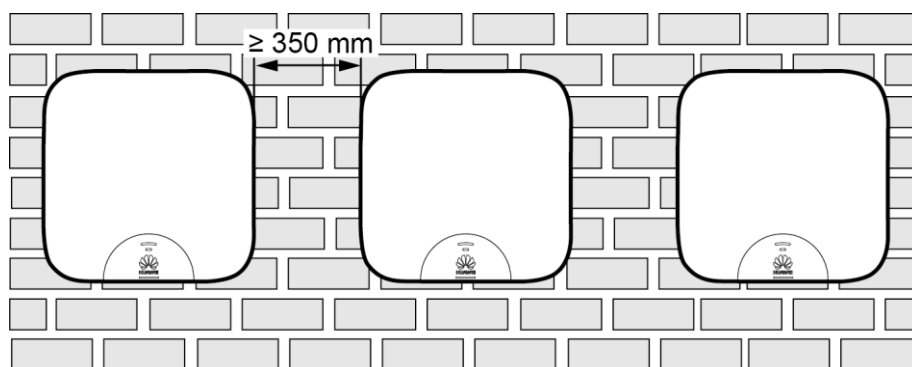
**Figure 4-2** Installation clearance requirements



IS05W00019

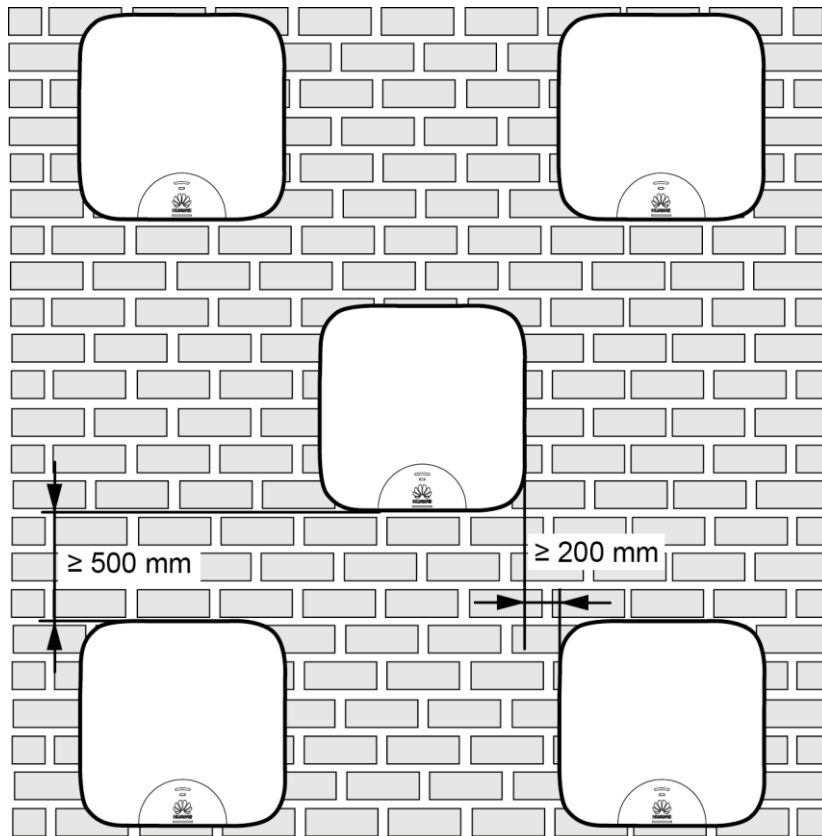
- When installing multiple SUN2000s, install them in horizontal mode if the space is sufficient and install them in staggered mode if the space is insufficient. Stacked installation is not recommended.

**Figure 4-3** Horizontal installation mode (recommended)



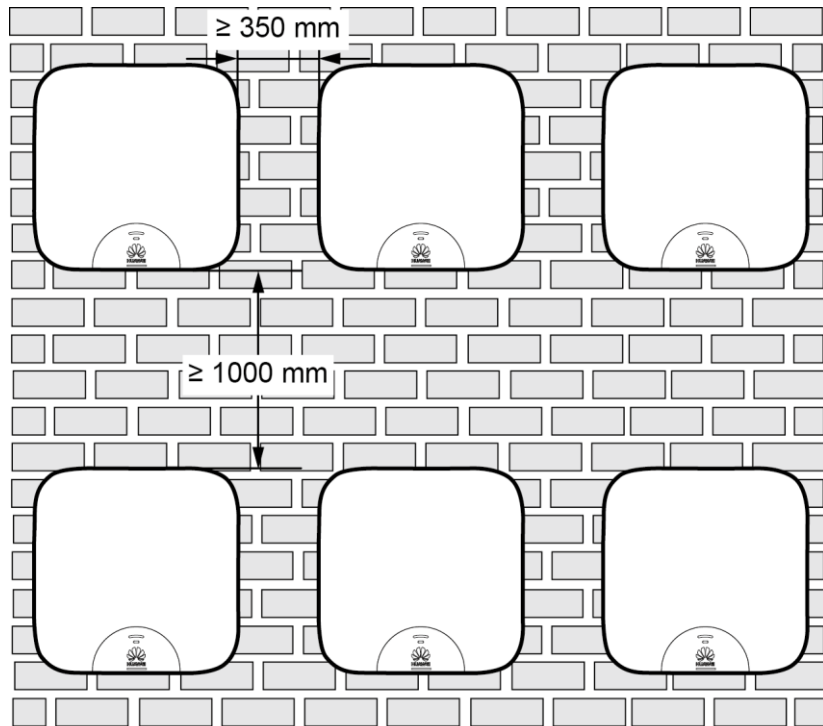
IS05W00015

**Figure 4-4** Staggered installation mode (recommended)



IS05W00017

**Figure 4-5** Stacked installation mode (not recommended)

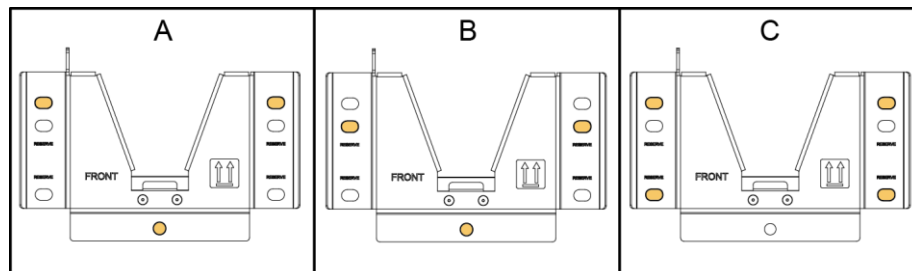


IS05W00016

## 4.4 Installing the Mounting Bracket

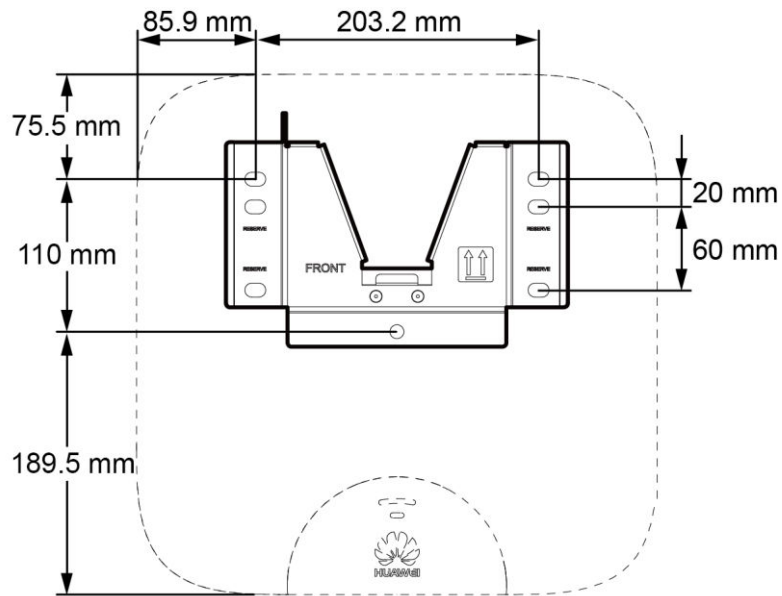
Fixing holes can be used in three combinations. Select a hole combination based on site requirements. Combination A is preferred.

**Figure 4-6** Hole combinations



IS05W00027

**Figure 4-7** Hole distances



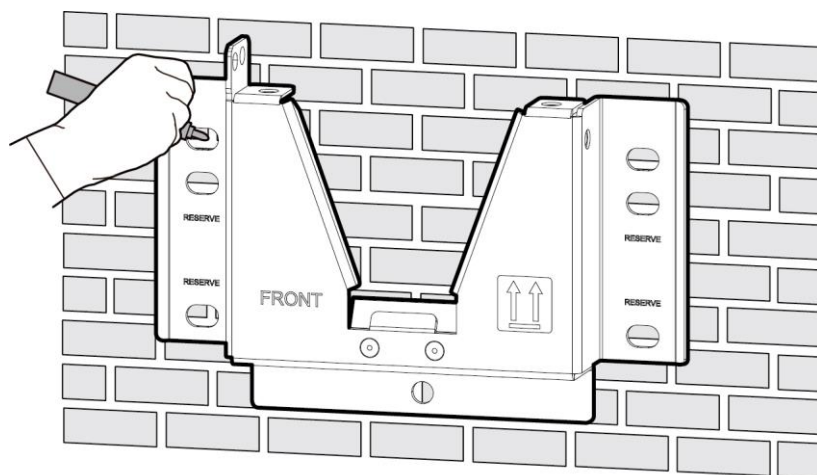
IS05W00021

## 4.4.1 Wall-Mounted Installation

### Procedure

- Step 1** Determine the positions for drilling holes using the mounting bracket. Level the positions of mounting holes using a bubble or digital level, and mark the positions with a marker.

**Figure 4-8** Determining hole positions



IS05H00017

- Step 2** Install expansion bolts.

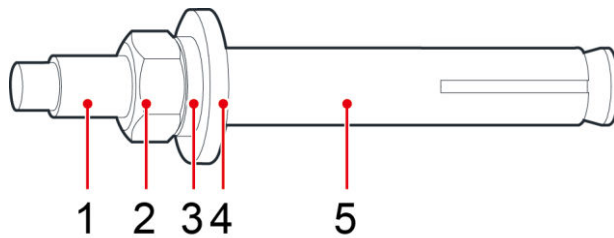
**⚠ DANGER**

Avoid drilling holes in the utility pipes and/or cables attached to back of the wall.

**📖 NOTE**

If the length or number of M8x80 expansion bolts supplied with the SUN2000 is not enough, prepare M8 stainless steel expansion anchor bolts.

**Figure 4-9** Expansion bolt composition



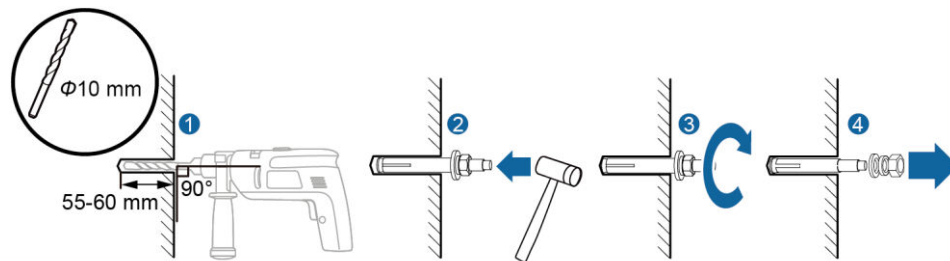
IS05W00018

- |                 |                      |                   |
|-----------------|----------------------|-------------------|
| (1) Bolt        | (2) Nut              | (3) Spring washer |
| (4) Flat washer | (5) Expansion sleeve |                   |

**NOTICE**

- To prevent dust inhalation or contact with eyes, wear safety goggles and an anti-dust respirator when drilling holes.
- Clean up any dust in and around the holes using a vacuum cleaner and measure the distance between holes. If the holes are inaccurately positioned, drill a new set of the holes.
- Level the head of the expansion sleeve with the concrete wall after removing the bolt, spring washer, and flat washer. Otherwise, the mounting bracket will not be securely installed on the concrete wall.

**Figure 4-10** Installing an expansion bolt

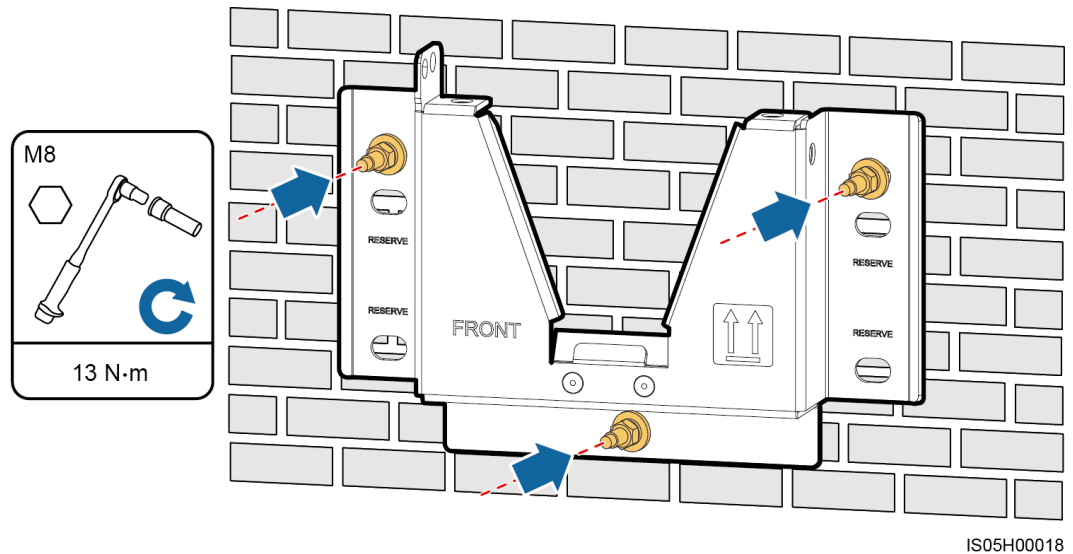


IS05H00021

**Step 3** Secure the mounting bracket.



**Figure 4-11** Securing a mounting bracket



----End

## 4.4.2 Support-mounted Installation

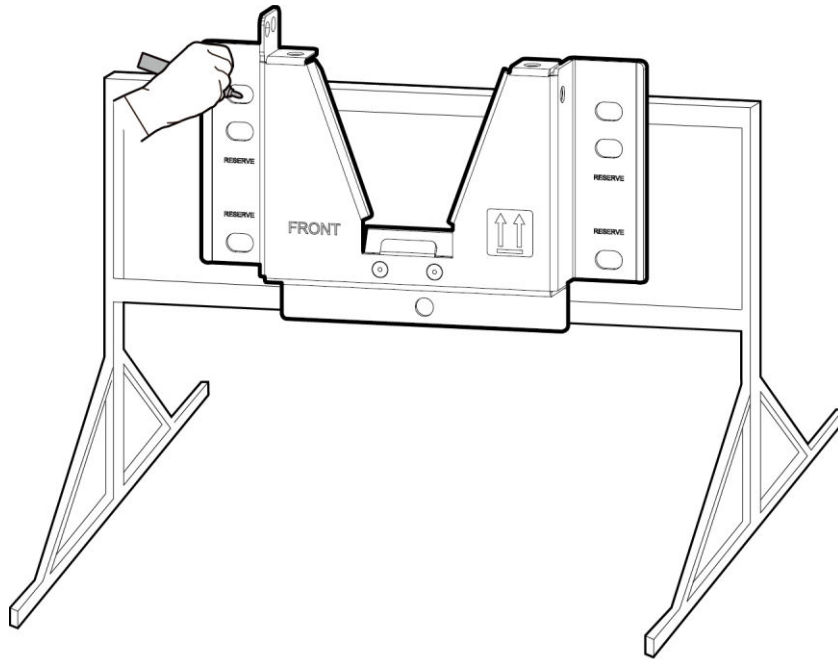
### Prerequisites

Prepare M8 stainless bolt assemblies (including flat washers, spring washers, and M8 bolts) with appropriate lengths as well as matched flat washers and nuts based on the support specifications.

### Procedure

- Step 1** Determine the positions for drilling holes using the mounting bracket. Level the positions of mounting holes using a bubble or digital level, and mark the positions with a marker.

**Figure 4-12** Determining hole positions



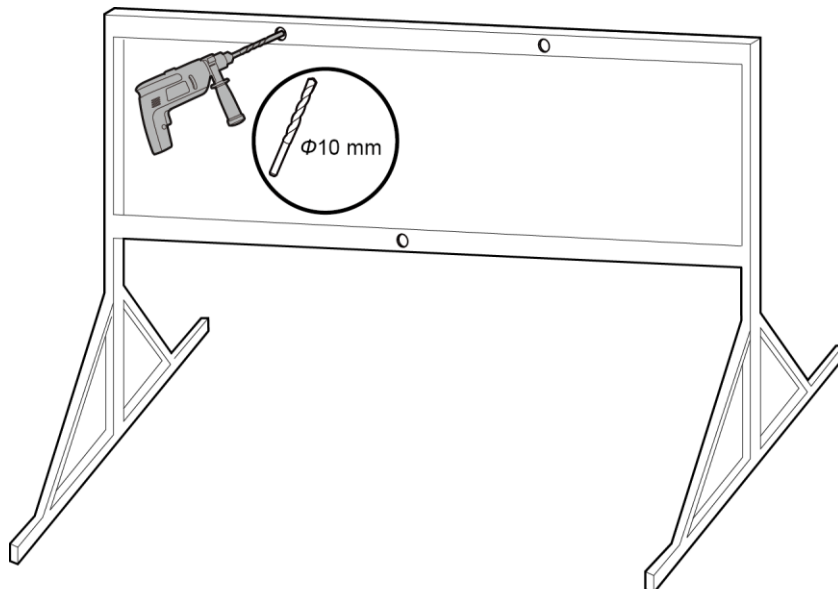
IS05H00020

**Step 2** Drill holes using a hammer drill.



**NOTE**  
You are advised to apply anti-rust paint on the hole positions for protection.

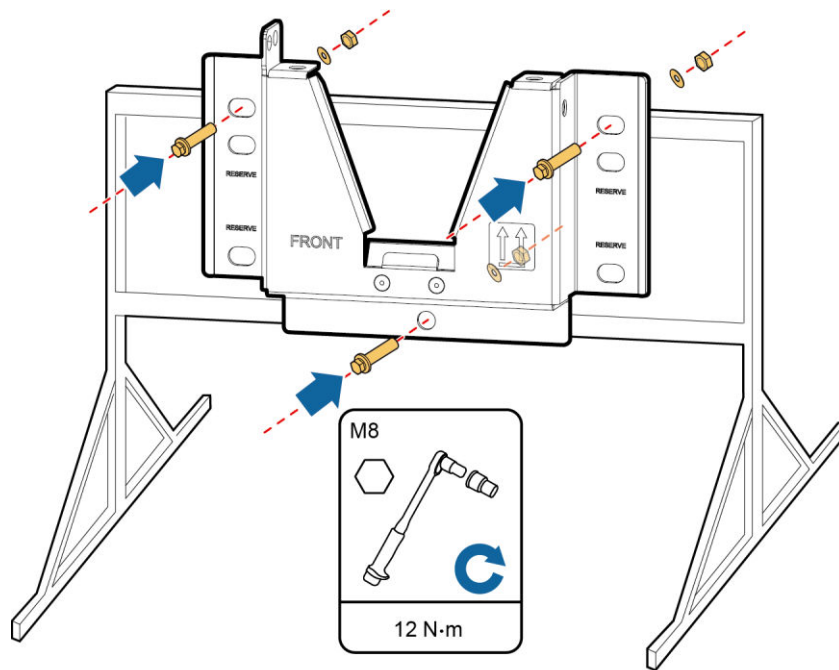
**Figure 4-13** Drilling holes



IS05H00022

**Step 3** Secure the mounting bracket.

**Figure 4-14** Securing a mounting bracket



IS05H00023

----End

## 4.5 Installing the SUN2000

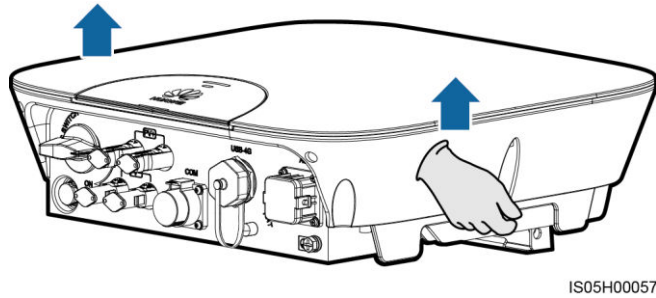
### Procedure

- Step 1** Hold the handles on both sides of the SUN2000, lift the SUN2000 from the packing case, and transport it to the installation position.

**CAUTION**

- To prevent device damage and personal injury, keep balance when moving the SUN2000.
- Do not use the ports and wiring terminals at the bottom to support any weight of the SUN2000.
- When you need to temporarily place the SUN2000 on the ground, use foam, paper or other protection material to prevent damage to its cover.

**Figure 4-15** Moving a SUN2000



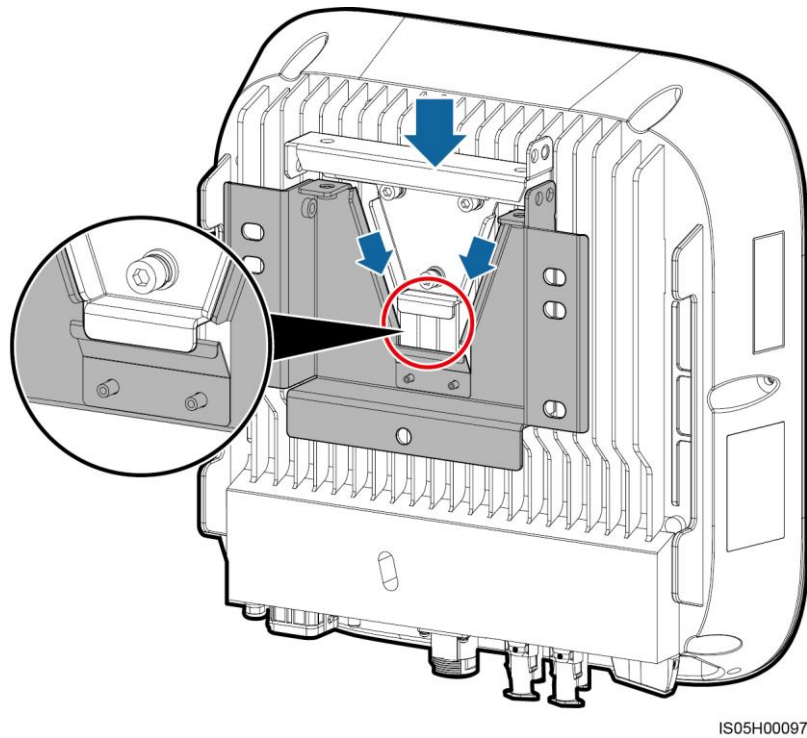
IS05H00057

- Step 2** Install the SUN2000 on the mounting bracket and align the SUN2000 enclosure with the mounting bracket.

**NOTICE**

If the bottom of the mounting plate does not snap into place, push the SUN2000 from the front until the bottom of the mounting plate snaps into the mounting bracket.

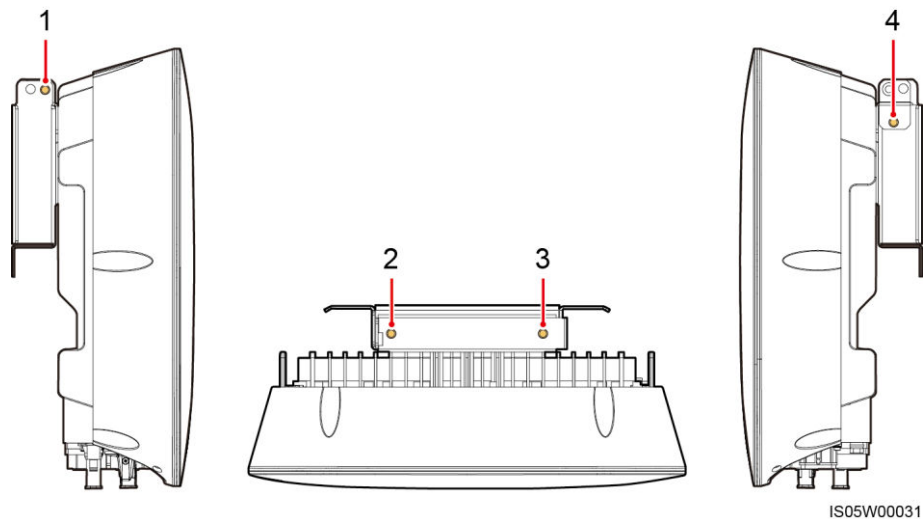
**Figure 4-16** Mounting a SUN2000



**Step 3** Tighten screw assemblies.

Fixing holes can be used in three combinations. Select a hole combination based on site requirements. Combination A is preferred.

**Figure 4-17** Fixing holes



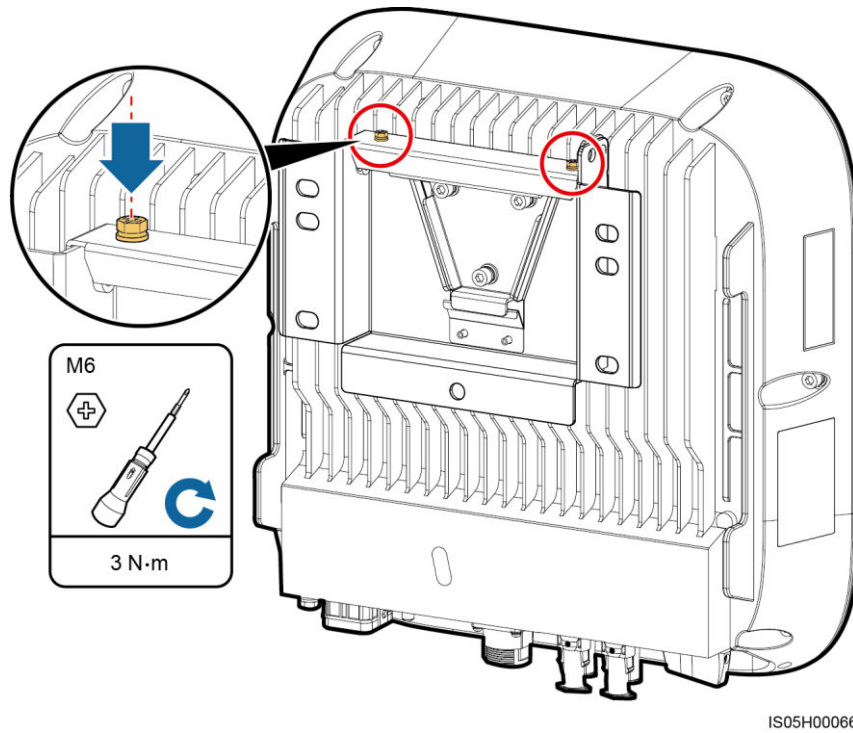
Combination A: holes 2 and 3

Combination B: holes 1 and 3

Combination C: holes 1 and 4

Combination D: holes 2 and 4

**Figure 4-18** Tightening screw assemblies



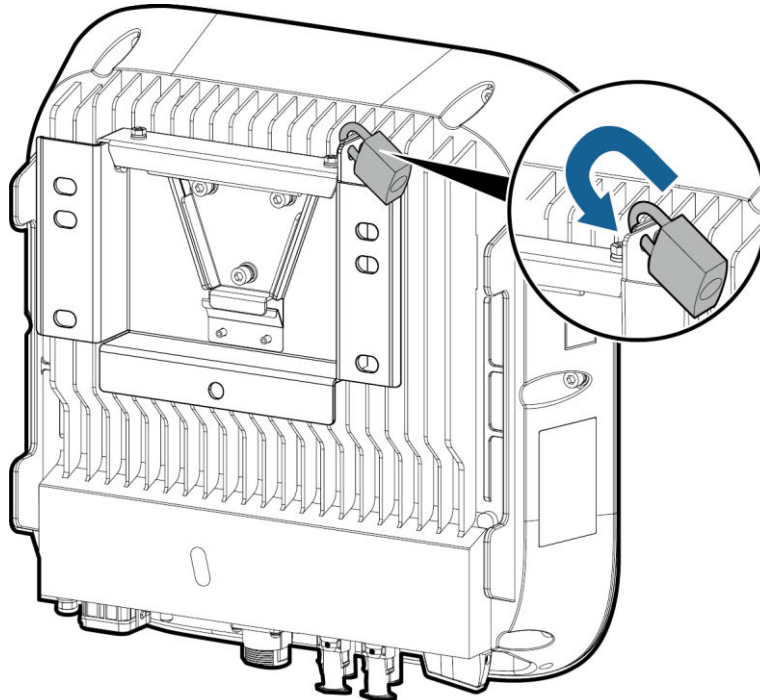
**Step 4** (Optional) Install an anti-theft lock.

The function of an anti-theft lock is to secure the SUN2000 to the mounting bracket and protect it from stealing.

**NOTICE**

- Prepare an anti-theft lock suitable for the lock hole diameter ( $\Phi 8$  mm) by yourself.
- Keep the key to the anti-theft lock safe.

**Figure 4-19** Installing an anti-theft lock



IS05H00067

----End

## 4.6 (Optional) Installing the WiFi Antenna

### Prerequisites

A WiFi antenna is configured.

### Context

The Smart Dongle and WiFi antenna cannot be used at the same time.

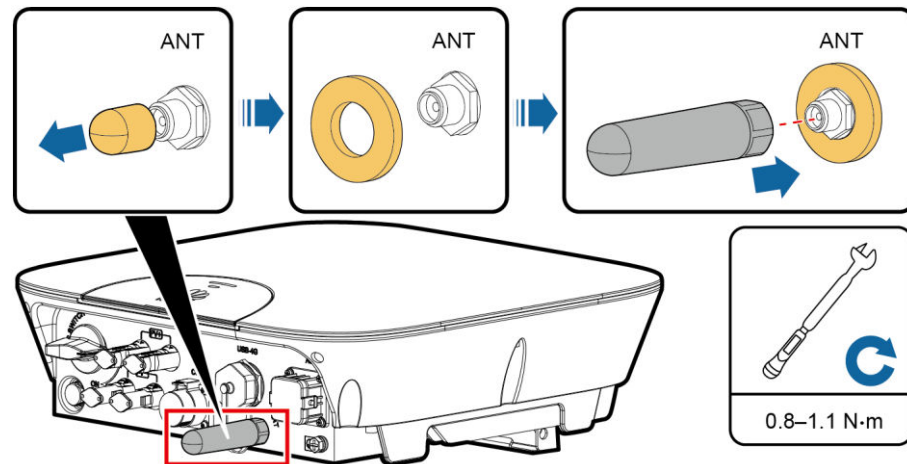
### Procedure

- Step 1** Remove the watertight cap from the ANT port.
- Step 2** Attach the washer to the enclosure.
- Step 3** Install the WiFi antenna.

**NOTICE**

Ensure that the WiFi antenna is installed securely.

**Figure 4-20** Installing a WiFi antenna



IS05H00011

----End

## 4.7 (Optional) Installing the 4G Smart Dongle

### Prerequisites

A 4G Smart Dongle is configured.

A subscriber identity module (SIM) card complying with the 4G Smart Dongle specifications is prepared.

Ensure that the SIM card is activated.

### Context

The Smart Dongle and WiFi antenna cannot be used at the same time.

**NOTICE**

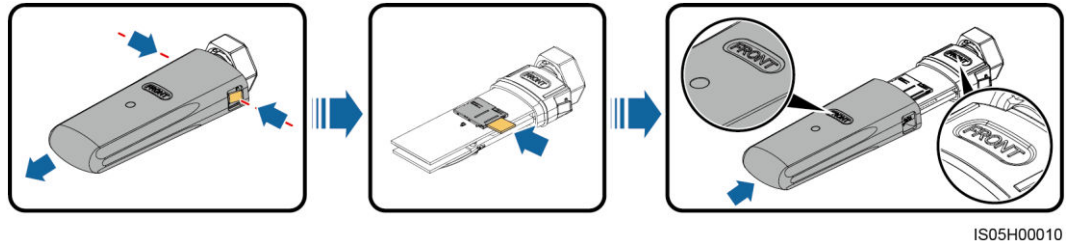
The USB-4G port can only be used for the access from a 4G Smart Dongle, rather than a USB data cable.



## Procedure

- Step 1** Press the buckle inwards to remove the 4G Smart Dongle enclosure, and then install the SIM card.

**Figure 4-21** Installing a SIM card

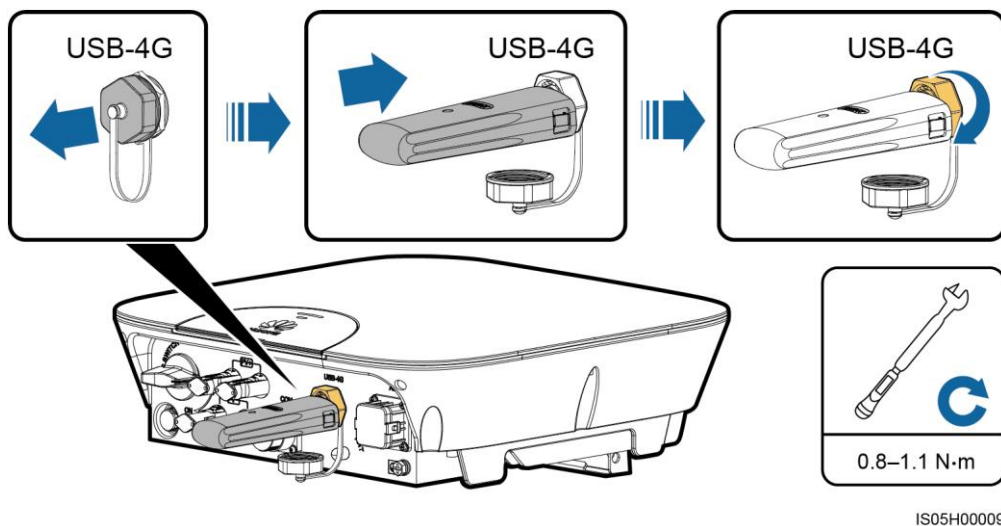


 **NOTE**

- When installing a SIM card, you can determine the SIM card installation direction based on the arrow mark on the slot.
- When being pressed into place, the SIM card will be locked, which means that the card is installed correctly.
- To remove the SIM card, push it inwards. Then the SIM card springs out automatically.
- When reinstalling the 4G Smart Dongle enclosure, ensure that the buckle springs back to the original position.

- Step 2** Remove the watertight cap from the USB-4G port and fix the 4G Smart Dongle.

**Figure 4-22** Fixing a 4G Smart Dongle



----End

---

# 5 Electrical Connections

---

## Precautions

---

 **DANGER**

Before connecting cables, ensure that the DC switch on the SUN2000 and all the switches connecting to the SUN2000 are OFF. Otherwise, the high voltage of the SUN2000 may result in electric shocks.

---

---

 **WARNING**

- The equipment damage caused by incorrect cable connections is beyond the warranty scope.
  - Only certified electricians are allowed to connect cables.
  - Operation personnel must wear proper PPE when connecting cables.
- 

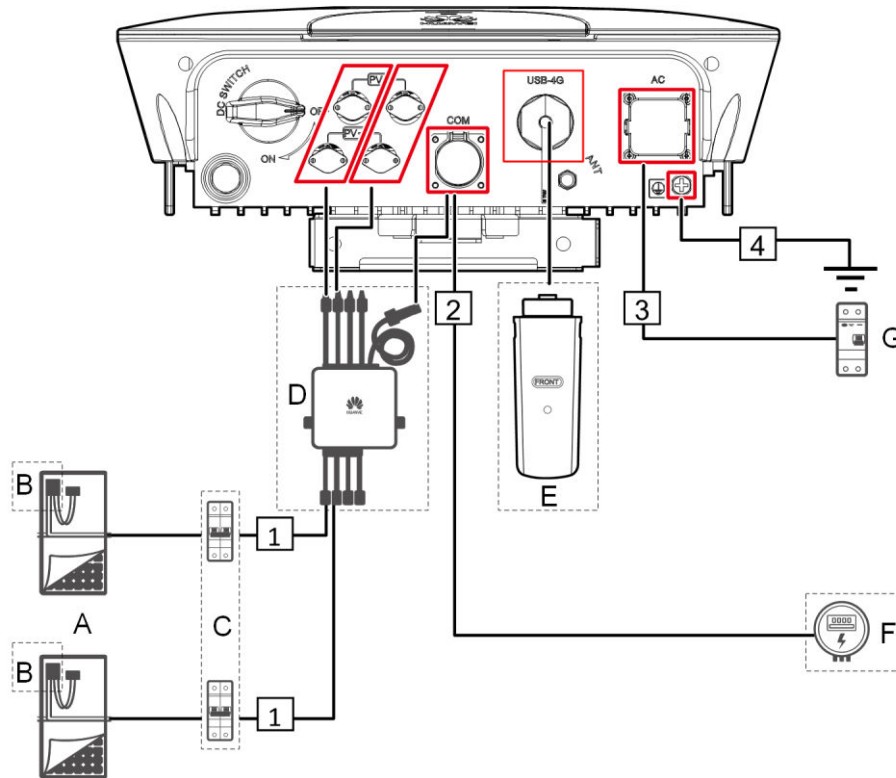


**NOTE**

The cable colors shown in the electrical connection diagrams provided in this chapter are for reference only. Select cables in accordance with local cable specifications (green-and-yellow cables are only used for PE).


## 5.1 Preparing Cables

**Figure 5-1** SUN2000 cable connections (dashed boxes indicate optional components)



**Table 5-1** Component description

No.	Component	Description	Source
A	PV string	<ul style="list-style-type: none"> <li>A PV string is composed of the PV modules connected in series and works with an optimizer.</li> <li>The SUN2000 supports the input from two PV strings.</li> </ul>	Purchased by the customer
B	Smart PV Optimizer	The Smart PV Optimizer that can connect to the SUN2000 is SUN2000P-375W.	Can be purchased from Huawei
C	DC switch	Recommended: a DC circuit breaker with a rated voltage greater than or equal to 600 V DC and a rated current of 20 A.	Purchased by the customer

No.	Component	Description	Source
D	Smart PV Safety Box	The Smart PV Safety Box that can connect to the SUN2000 is SmartPSB2000L.	Can be purchased from Huawei
E	4G Smart Dongle <sup>a</sup>	The 4G Smart Dongle that can connect to the SUN2000 is SDongleA-03.	Can be purchased from Huawei
F	Smart Power Sensor	The Smart Power Sensor that can connect to the SUN2000 are DDSU666-H, DTSU666-H, CCS-WNC-3Y-400-MB, Gavazzi-EM340DINAV23X S1X08, Gavazzi-EM112DINAV01X S1X08, and Gavazzi-EM111DINAV81X S1X08.	Purchased by the customer
G	AC switch	Recommended: a single-phase AC circuit breaker with a rated voltage greater than or equal to 250 V AC and a rated current of <ul style="list-style-type: none"> <li>• 25 A (SUN2000-2KTL-L0 and SUN2000-3KTL-L0)</li> <li>• 32 A (SUN2000-4KTL-L0 and SUN2000-5KTL-L0)</li> </ul>	Purchased by the customer
<p>Note a: For details about the SDongleA-03 operation, see <a href="#">SDongleA-03 Quick Guide (4G)</a>. You can also scan the QR code to obtain it.</p> 			

**NOTICE**

- The SUN2000 is embedded with a residual current monitoring unit (RCMU). Only a single-phase circuit breaker or a similar AC load breaking device is required to function as the external AC switch (shown by G in Figure 5-1) to ensure that the SUN2000 can be safely disconnected from the power grid.
- If the external AC switch can perform earth leakage protection, the rated leakage action current should be greater than or equal to 100 mA.
- If multiple SUN2000s connect to the general residual current device (RCD) through their respective external AC switches, the rated leakage action current of the general RCD should be greater than or equal to the number of SUN2000s multiplied by 100 mA.
- A knife switch cannot be used as an AC switch.

**Table 5-2** Cable description

No.	Cable	Type	Conductor Cross-sectional Area Range	Outer Diameter	Source
1	DC input power cable	Standard PV cable in the industry (recommended model: PV1-)	4–6 mm <sup>2</sup>	4.5–7.8 mm	Purchased by the customer
2	Smart Power Sensor signal cable	Four-core outdoor shielded twisted pair cable	0.25–1 mm <sup>2</sup>	4–11 mm	Purchased by the customer
3	AC output power cable	<ul style="list-style-type: none"> <li>• Not using the PE equipotential point at the AC output port: two-core (L and N) outdoor copper cable</li> <li>• Using the PE equipotential point at the AC output port: three-core (L, N, and PE) outdoor copper cable</li> </ul>	4–6 mm <sup>2</sup>	10–21 mm	Purchased by the customer
4	PE cable	Single-core outdoor copper cable with an M6 OT terminal	4–10 mm <sup>2</sup>	N/A	Purchased by the customer

---

**NOTICE**

- The PE point at the AC output port is used only as a PE equipotential point, and cannot substitute for the PE point on the enclosure.
  - When installing cables, ensure that the AC output power cable and PE cable are close to each other.
  - When installing cables, ensure that the AC output power cable and DC input power cables are close to each other.
  - When installing DC input power cables, ensure that the PV+ and PV– cables are close to each other.
- 

## 5.2 Installing the PE Cable

### Context

---

** DANGER**

Do not connect the neutral wire to the enclosure as a PE cable. Otherwise, electric shocks could occur.

---

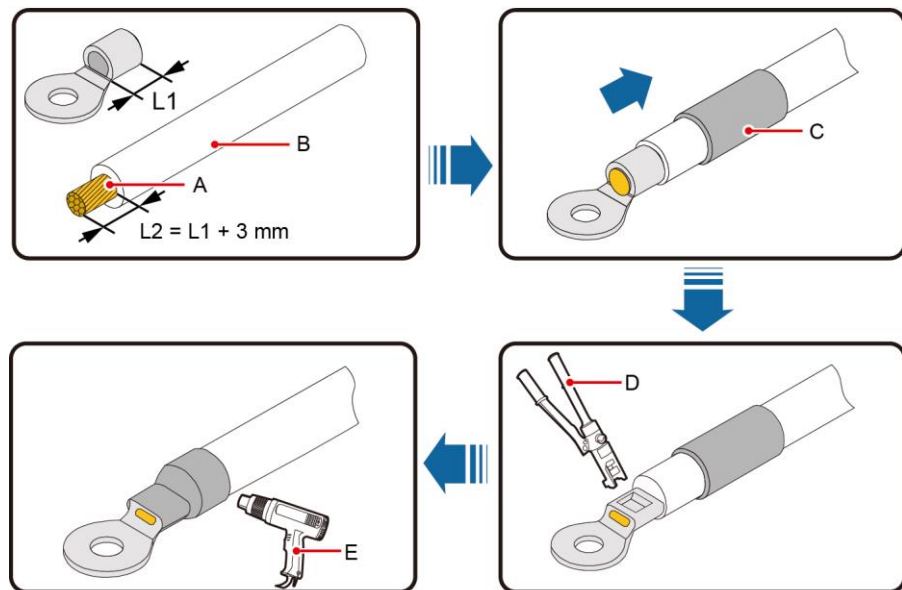
### Procedure

- Step 1** Crimp the OT terminal.

**NOTICE**

- Pay attention not to damage the core wire when stripping a cable.
- The cavity formed after the conductor crimp strip of the OT terminal is crimped must wrap the core wires completely. The core wires must contact the OT terminal closely.
- Wrap the wire crimping area with heat shrink tubing or PVC insulation tape. The following figure uses heat shrink tubing as an example.
- When using the heat gun, protect devices from being scorched.

**Figure 5-2** Crimping an OT terminal



IS05200001

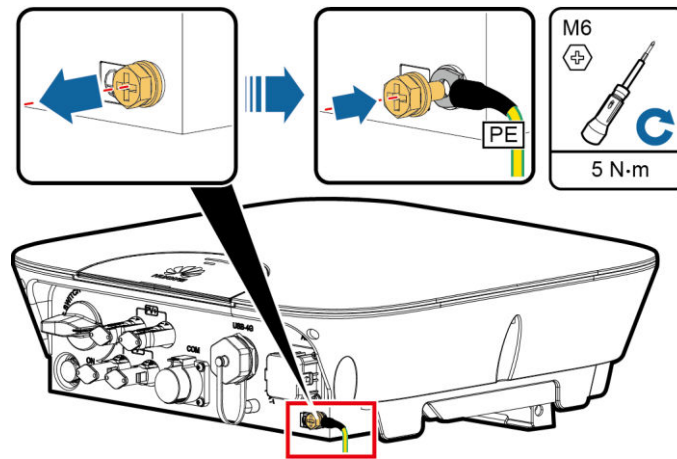
- (A) Core wire                      (B) Insulation layer                      (C) Heat shrink tubing  
(D) Hydraulic pliers                      (E) Heat gun

**Step 2** Connect the PE cable.

**NOTICE**

Ensure that the PE cable is connected securely.

**Figure 5-3** Connecting a PE cable



IS05H00012

**NOTE**

- The PE point at the AC output port is used only as a PE equipotential point, and cannot substitute for the PE point on the enclosure.
- To enhance the corrosion resistance of a ground terminal, apply silica gel or paint around the terminal after connecting the PE cable.

----End

## 5.3 Installing the AC Output Power Cable

### Prerequisites

An AC switch must be installed on the AC side of the SUN2000 to ensure that the SUN2000 can be safely disconnected from the power grid.

**WARNING**

Do not connect any load between the SUN2000 and the AC switch.

### Context

The SUN2000 can detect the grounding. This function is used to detect whether the SUN2000 is properly grounded before starting it, or to detect whether the PE cable is disconnected when the SUN2000 is working. This function is available only under limited conditions. To ensure the safe operation of the SUN2000, properly ground the SUN2000 in strict accordance with the connection requirements for PE cables. For certain types of power grids, if an isolation transformer connects to the output side of the SUN2000, you need to set **Grounding inspection** to **Disable** after checking that the SUN2000 is properly grounded. Then the SUN2000 can start normally. If you are not sure whether the SUN2000 connects to such a power grid, confirm it with your supplier or Huawei technical support.



 **NOTE**

- According to IEC62109, to ensure the safe operation of the SUN2000 in the case of PE cable damage or disconnection, connect the SUN2000 PE cable according to the requirements described in [5.2 Installing the PE Cable](#) and ensure that the SUN2000 PE cable meets at least one of the following requirements before disabling the grounding detection function.

The SUN2000 PE cable is a copper cable with a cross-sectional area of at least 10 mm<sup>2</sup>.

Use two cables that have the same diameter as the AC output power cable to ground the PE terminal on the AC connector and the ground screw on the enclosure respectively (see [5.2 Installing the PE Cable](#) and [5.3 Installing the AC Output Power Cable](#) for details).

- Certain countries require an additional PE cable for the SUN2000. In this case, use two cables that have the same diameter as the AC output power cable to ground the PE terminal on the AC connector and the ground screw on the enclosure respectively (see [5.2 Installing the PE Cable](#) and [5.3 Installing the AC Output Power Cable](#) for details).

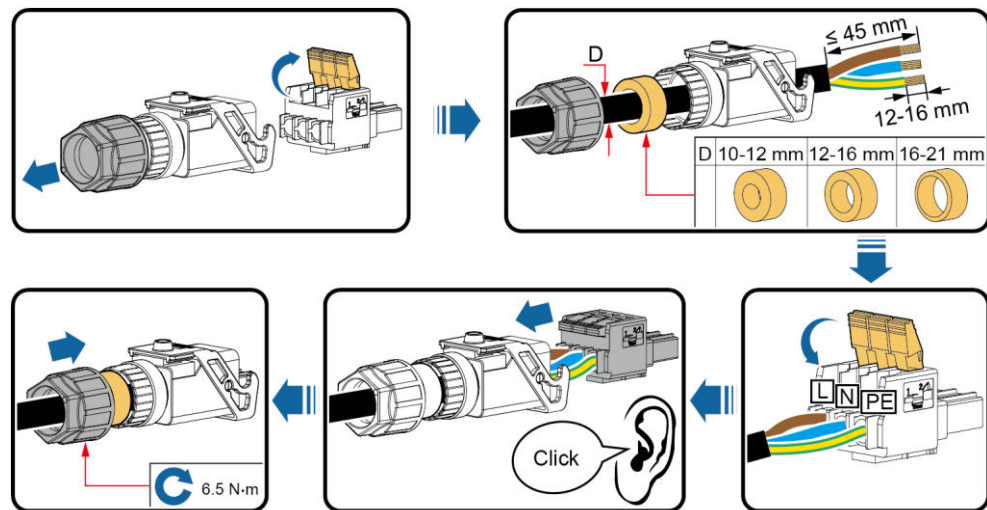
## Procedure

**Step 1** Connect the AC output power cable to the AC connector.

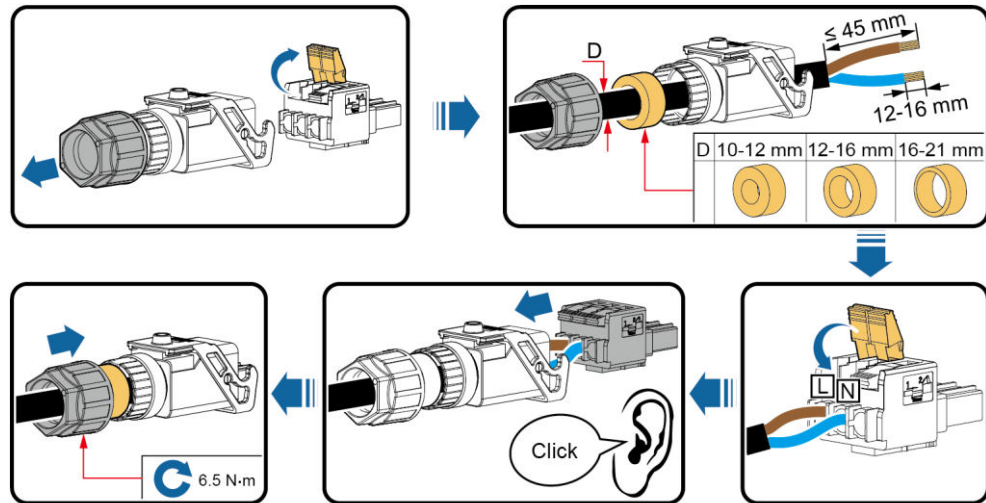
**NOTICE**

- Ensure that the cable jacket is inside the connector.
- Ensure that the exposed core wire is totally inserted into the cable hole.
- Ensure that AC terminations provide firm and solid electrical connections. Failing to do so may cause SUN2000 malfunction and damage to its AC connectors.
- Ensure that the cable is not twisted.

**Figure 5-4** Assembling an AC connector (three-core wire)



**Figure 5-5** Assembling an AC connector (two-core wire)

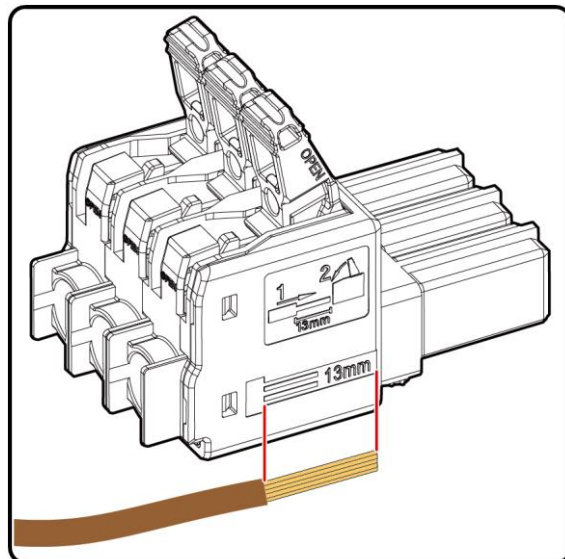


IH0120001

**NOTE**

- The cable colors shown in figures are for reference only. Select an appropriate cable according to the local standards.
- For the core wire installation method and stripped length, see the instructions on the side of the plug insert.

**Figure 5-6** Stripped length



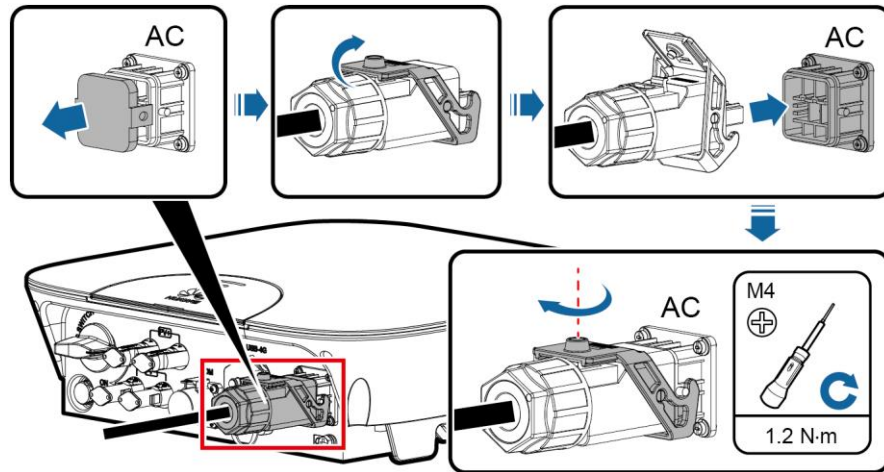
IS05W00036

**Step 2** Connect the AC connector to the AC output port.

**NOTICE**

Ensure that the AC connector is connected securely.

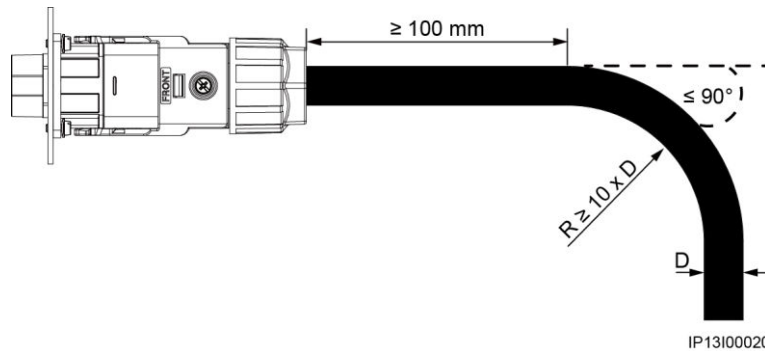
**Figure 5-7** Securing an AC connector



IS05H00027

**Step 3** Check the route of the AC output power cable.

**Figure 5-8** Cable route



IP13100020

----End

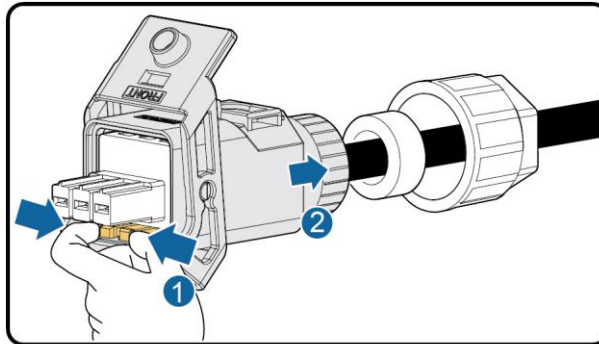
## Follow-up Procedure

**WARNING**

Before removing the AC connector, ensure that the DC switch at the bottom of the SUN2000 and all the switches connecting to the SUN2000 are OFF.

To remove the AC connector from the SUN2000, perform the operations in reverse order.

**Figure 5-9** Removing a plug insert



IS05H00031

## 5.4 Installing the DC Input Power Cable

### Prerequisites

---

**⚠ DANGER**

- Before connecting the DC input power cable, ensure that the DC voltage is within the safe range (lower than 60 V DC) and that the DC switch on the SUN2000 is OFF. Failing to do so may result in electric shocks.
  - When the SUN2000 is operating, it is not allowed to work on DC circuit, such as connecting or disconnecting a PV string or a PV module in a PV string. Failing to do so may cause electric shocks.
  - If no PV string connects to the DC input terminals, do not remove the watertight cap from the DC input terminals. Otherwise, the SUN2000 will not comply with its Ingress Protection Rating.
- 

**⚠ WARNING**

Ensure that the following conditions are met. Otherwise, the SUN2000 will be damaged, or even become a fire hazard.

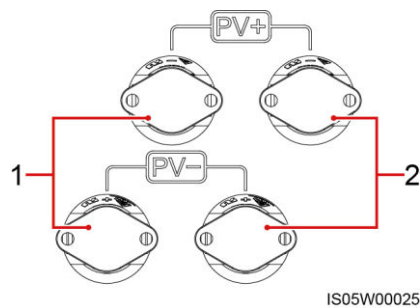
- The open-circuit voltage of each PV string is always lower than or equal to 600 V DC.
  - The positive and negative terminals of a PV string connect to corresponding positive and negative DC input terminals of the SUN2000.
  - If polarity of the DC input power cable is reversed and the DC switch is ON, do not turn off the DC switch immediately or unplug positive and negative connectors. Wait until the solar irradiance declines at night and the PV string current reduces to below 0.5 A, and then turn off the DC switch and remove the positive and negative connectors. Correct the string polarity before reconnecting the string to the SUN2000.
-

**NOTICE**

- The PV terminal of the inverter supports only the PV string input and cannot be connected to other power supplies. Since the output of the PV string connected to the SUN2000 cannot be grounded, ensure that the PV module output is well insulated to ground.
- During the installation of PV strings and SUN2000, the positive or negative terminals of PV strings may be grounded if power cables are not properly installed or routed. In this case, an AC or DC short circuit may occur and damage the SUN2000. This damage is not covered under any warranty.

## Context

**Figure 5-10** DC input terminals



(1) The first set of DC input terminals

(2) The second set of DC input terminals

## Procedure

- Step 1** Assemble the black positive and negative connectors.

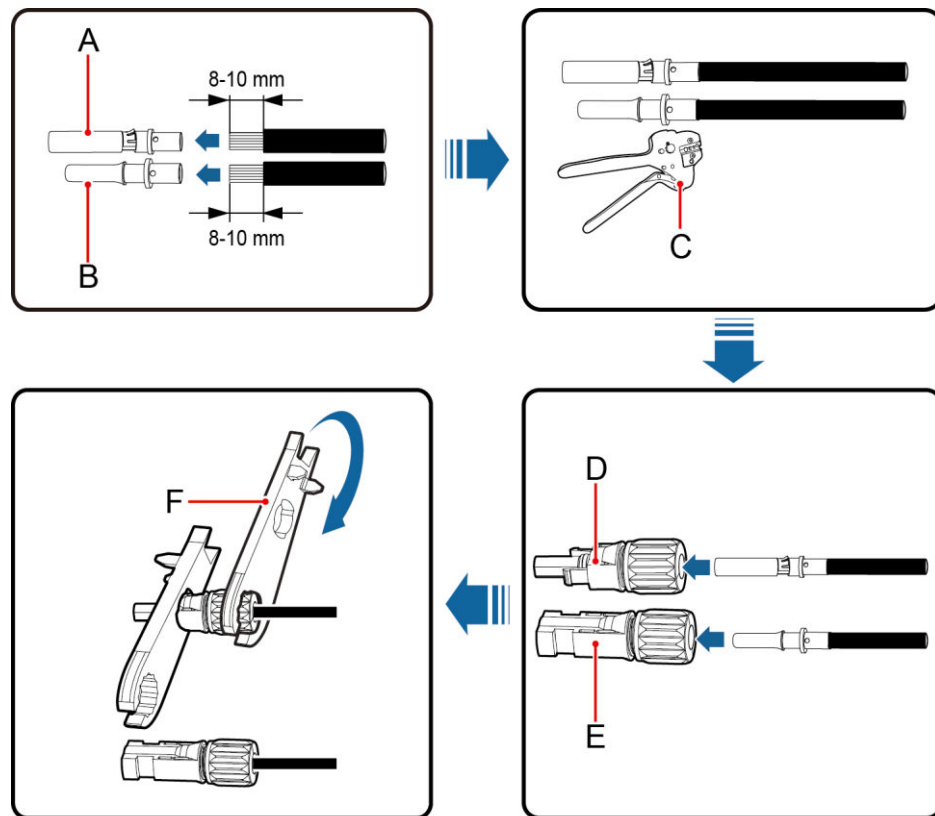
**CAUTION**

Use the positive and negative metal contacts and DC connectors supplied with the SUN2000. Using incompatible positive and negative metal contacts and DC connectors may result in serious consequences. The caused device damage is not covered under any warranty.

**NOTICE**

- Cables with high rigidity, such as armored cables, are not recommended as DC input power cables, because poor contact may be caused by the bending of the cables.
- The metal contacts supplied with the DC connectors are either cold forming contacts or stamping forming contacts. Crimp the metal cold forming contacts using crimping tool UTXTC0005 (Amphenol, recommended) or H4TC0001 (Amphenol). Crimp the metal stamping forming contacts using crimping tool H4TC0003 (Amphenol, recommended) or H4TC0002 (Amphenol).
- Before assembling DC input connectors, label the cable polarities correctly to ensure correct cable connections.
- After crimping the positive and negative metal contacts, pull the DC input power cables back to check that they are connected securely.
- Insert the crimped metal contacts of the positive and negative power cables into the corresponding positive and negative connectors. Then pull back the DC input power cables to check that they are connected securely.

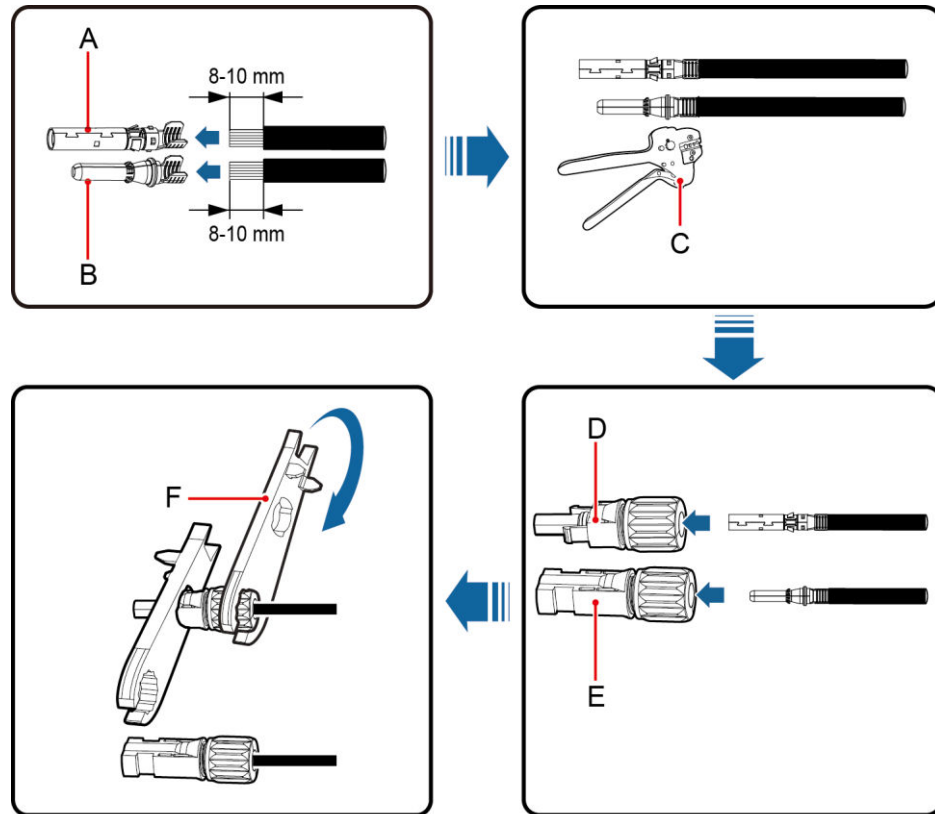
**Figure 5-11** Assembling DC connectors (using metal cold forming contacts)



IS03H00021

- |                            |                            |                              |
|----------------------------|----------------------------|------------------------------|
| (A) Positive metal contact | (B) Negative metal contact | (C) UTXTC0005 crimping tool  |
| (D) Positive connector     | (E) Negative connector     | (F) H4TW0001 open-end wrench |

**Figure 5-12** Assembling DC connectors (using metal stamping forming contacts)



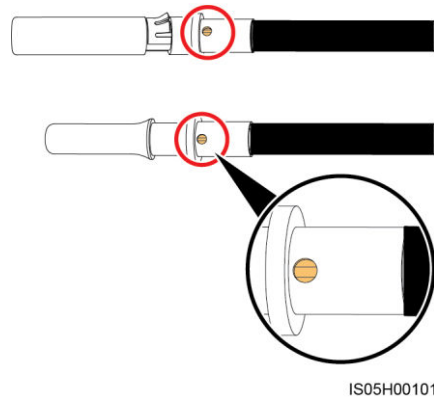
IS03H00021

- |                            |                            |                              |
|----------------------------|----------------------------|------------------------------|
| (A) Positive metal contact | (B) Negative metal contact | (C) H4TC0003 crimping tool   |
| (D) Positive connector     | (E) Negative connector     | (F) H4TW0001 open-end wrench |

**NOTICE**

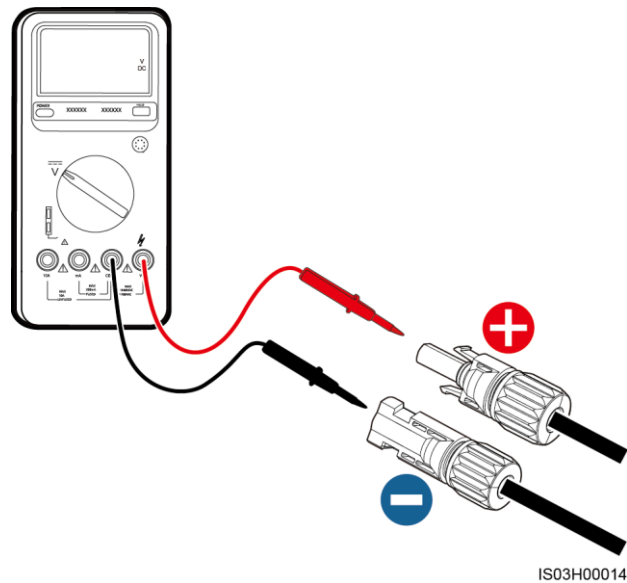
Ensure that the core wires can be seen through the hole on the terminal both before and after the positive and negative metal terminals are crimped.

**Figure 5-13** Observing core wires through the hole on the terminal



**Step 2** Ensure that the DC input voltage of each PV string is within the specified range of the SUN2000 using a multimeter and check that the polarities of DC input power cables are correct.

**Figure 5-14** Measuring the DC input voltage



Before performing [Step 3](#), ensure that the DC switch is OFF.

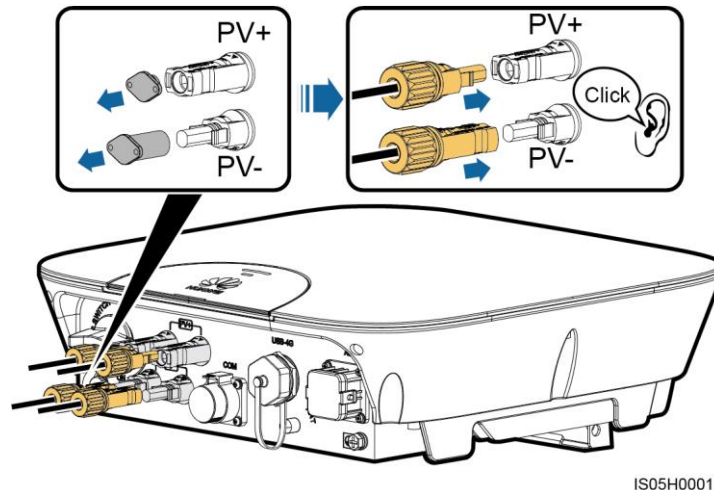
**Step 3** Insert the positive and negative connectors into corresponding DC input terminals on the SUN2000.



**NOTICE**

After the positive and negative connectors snap into place, pull the DC input power cables back to check that they are connected securely.

**Figure 5-15** Connecting DC input power cables



**NOTICE**

If polarity of the DC input power cable is reversed and the DC switch is ON, do not turn off the DC switch immediately or unplug positive and negative connectors. The device may be damaged if you do not follow the instruction. This damage is not covered under any warranty. Wait until the solar irradiance declines at night and the PV string current reduces to below 0.5 A, and then turn off the DC switch and remove the positive and negative connectors. Correct the string polarity before reconnecting the string to the SUN2000.

----End

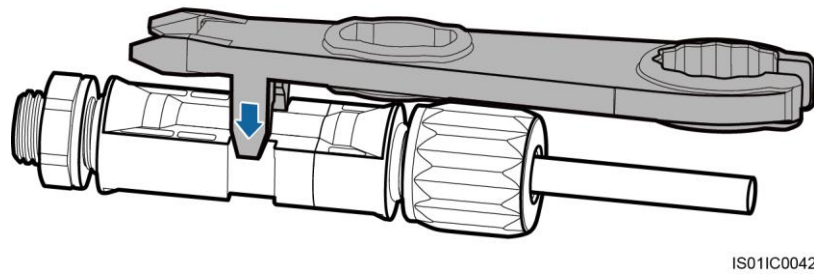
## Follow-up Procedure

**WARNING**

Before removing the positive and negative connectors, ensure that the DC switch is OFF.

To remove the positive and negative connectors from the SUN2000, insert an open-end wrench into the notch and press the wrench with an appropriate force.

**Figure 5-16** Removing a DC connector



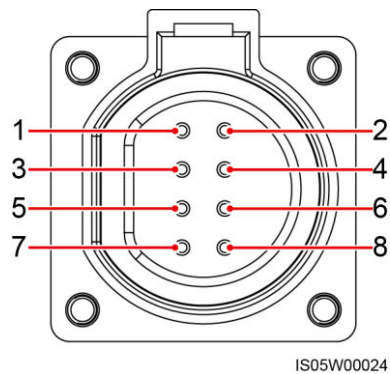
## 5.5 Installing the Signal Cable

### Context

#### NOTICE

- When laying out signal cables, separate them from power cables to avoid strong signal interference sources.
- The shield layer of the device signal cable connected to the COM port is also advised to be grounded.

**Figure 5-17** COM port



**Table 5-3** COM port pin definitions

No.	Label	Definition	Description
1	485B1	RS485B, RS485 differential signal-	Connects to the RS485 signal port on the power collector.
2	485A1	RS485A, RS485 differential signal+	

No.	Label	Definition	Description
3	485B2	RS485B, RS485 differential signal-	Reserved, can connect to the RS485 signal port on SmartPSB2000L Smart PV Safety Box.
4	485A2	RS485A, RS485 differential signal+	
5	12V-	Negative polarity of the 12 V power port	
6	12 V+	Positive polarity of the 12 V power port	
7	N/A	N/A	N/A
8	PE	Port for grounding the shield layer	Connects to the shield layer of the cable.

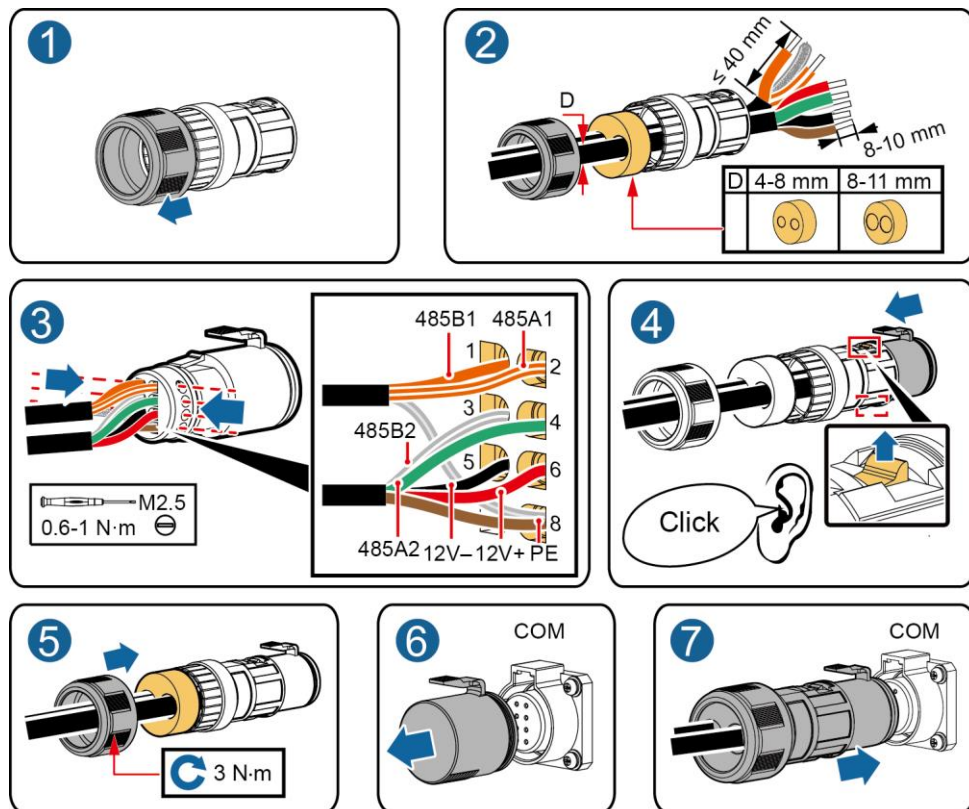
## Procedure

**Step 1** Connect signal cables to appropriate signal connectors.

**NOTICE**

- Ensure that the cable jacket is inside the connector.
- Ensure that the exposed core wire is totally inserted into the cable hole.
- Ensure that the signal cables are connected securely.
- Ensure that no cable is twisted.
- If two signal cables are required, ensure that they have the same outer diameter.

**Figure 5-18** Assembling a signal connector

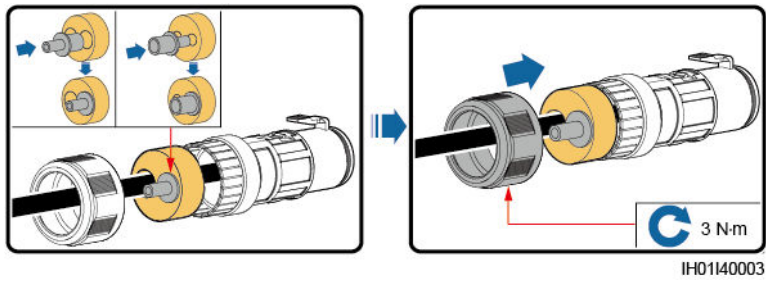


IH05140025

**NOTICE**

This document takes the connection of two signal lines as an example. If only one signal cable needs to be connected, block the unused cable hole on the seal using a cap and tighten the cable gland.

**Figure 5-19** Installing a cap

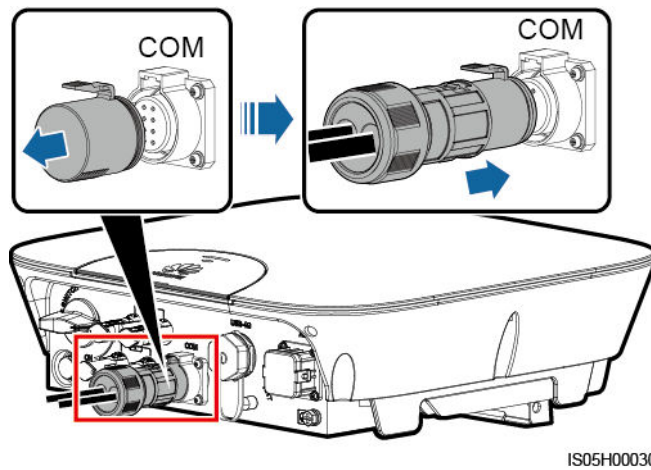


**Step 2** Connect the signal connector to the corresponding port.

**NOTICE**

Ensure that the signal connector is connected securely.

**Figure 5-20** Securing a plug



----End

# 6 System Commissioning

## 6.1 Checking Before Power-On

**Table 6-1** Installation checklist

No.	Check Item	Acceptance Criteria
1	SUN2000 installation	The SUN2000 is installed correctly, securely, and reliably.
2	Installation of the WiFi antenna or 4G Smart Dongle	The WiFi antenna or 4G Smart Dongle is installed correctly, securely, and reliably.
3	Cable layout	Cables are routed properly as required by the customer.
4	Cable tie	Cable ties are secured evenly and no burr exists.
5	Grounding	The ground cable is connected correctly, securely, and reliably.
6	DC switch	The DC switch and all the switches connecting to the SUN2000 are OFF.
7	Cable connections	The AC output power cable, DC input power cable, and signal cable are connected correctly, securely, and reliably.
8	Unused terminals and ports	Unused terminals and ports are locked by watertight caps.
9	Installation environment	The installation space is proper, and the installation environment is clean and tidy, without foreign matter.

## 6.2 Powering On the System

### Prerequisites

Before turning on the AC switch between the SUN2000 and the power grid, check that the AC voltage on the power grid side of the AC switch is within the specified range.

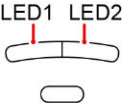
#### NOTICE

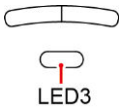
If the DC is on and the AC is off, the SUN2000 reports a **Grid Failure** alarm. The SUN2000 starts normally only after the fault is rectified.

### Procedure

- Step 1** Turn on the AC switch between the SUN2000 and the power grid.
- Step 2** Turn on the DC switch between the PV string and the SUN2000 if there is any.
- Step 3** Turn on the DC switch at the bottom of the SUN2000.
- Step 4** Observe the LEDs to check the SUN2000 operating status.

**Table 6-2** LED description

Type	Status		Meaning
Running indication LED1 LED2 	<b>LED 1</b>	<b>LED 2</b>	N/A
	Steady green	Steady green	The SUN2000 is exporting power to the power grid.
	Blinking green at long intervals (on for 1s and then off for 1s)	Off	The DC is on and the AC is off.
	Off	Blinking green at long intervals (on for 1s and then off for 1s)	The DC is off and the AC is on.
	Blinking green at long intervals (on for 1s and then off for 1s)	Blinking green at long intervals (on for 1s and then off for 1s)	Both the DC and AC are on, and the SUN2000 is not exporting power to the power grid.

Type	Status		Meaning
	Off	Off	Both the DC and AC are off, or the SUN2000 is in low power consumption mode which means that the monitoring system of the SUN2000 hibernates.
	Steady red	Steady red	The SUN2000 is faulty
Communicati on indication 	<b>LED 3</b>		N/A
	Blinking green at short intervals (on for 0.2s and then off for 0.2s)		Communicating (Communicating refers to that the communication with the upper-level management unit is in progress. However, if a mobile phone accesses the SUN2000, the LED indicates the "mobile phone access status: blinking green at long intervals" first.)
	Blinking green at long intervals (on for 1s and then off for 1s)		The mobile phone has connected to the SUN2000.
	Off		No communication

----End

## 6.3 Commissioning

### 6.3.1 Scenario 1: Commissioning Through Setup Wizard

#### Downloading the App

Search for "FusionSolar" from the following app stores or scan the corresponding QR code, download the installation package, and install the FusionSolar app by following the instructions.

- Google Play (Android)
- App Store (iOS)



Figure 6-1 QR code



 **NOTE**

- The screenshots shown in the document are from FusionSolar 2.3.0. Data in the screenshots is for reference only. The actual screens prevail.
- The initial password for connecting the inverter WiFi is **Changeme**
- The initial password of the **installer** is **00000a**.
- Use the initial password upon first power-on and change it immediately after login. To ensure account security, change the password periodically and keep the new password in mind. Not changing the initial password may cause password disclosure. A password left unchanged for a long period of time may be stolen or cracked. If a password is lost, devices cannot be accessed. In these cases, the user is liable for any loss caused to the PV plant.

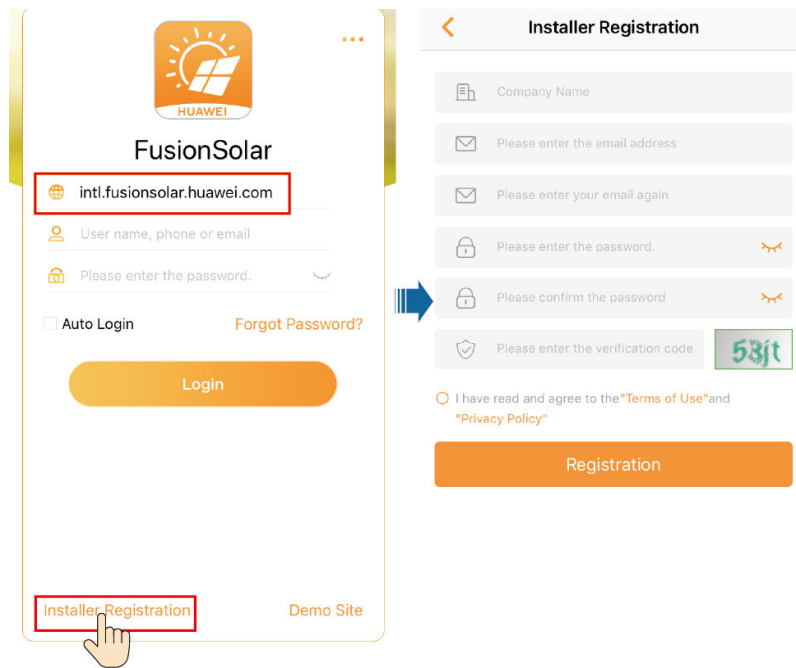
## (Optional) Installer Account Registration

Creating the first installer account will generate a domain named after the company.

 **NOTE**

If you have an installer account, skip this step.

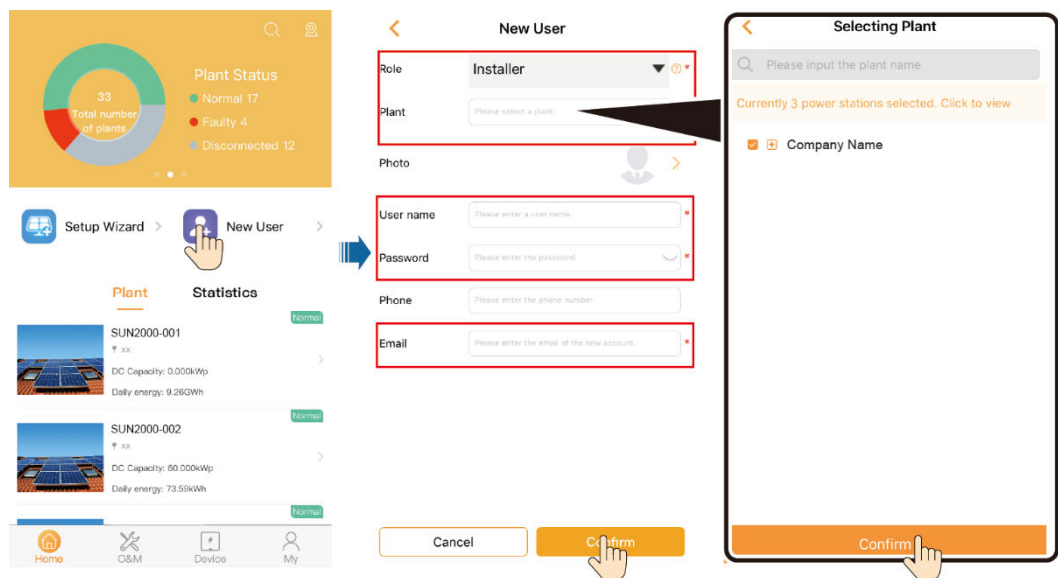
**Figure 6-2** Creating the first installer account



**NOTICE**

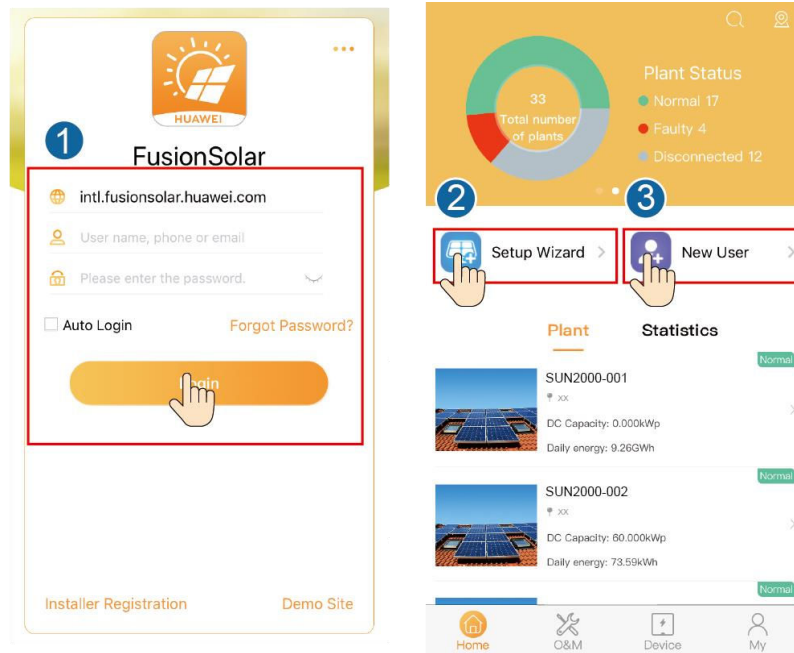
To create multiple installer accounts for the same company, log in to the FusionSolar app and tap **New User**.

**Figure 6-3** Creating multiple installer accounts for the same company



## Creating a PV Plant and an Account for User

Figure 6-4 Creating a PV Plant and an Account for User



### NOTE

For details, see the [FusionSolar App Quick Guide](#).

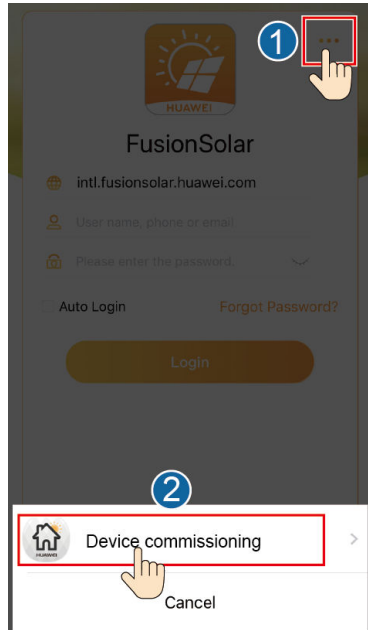
You can scan the QR code to obtain it.



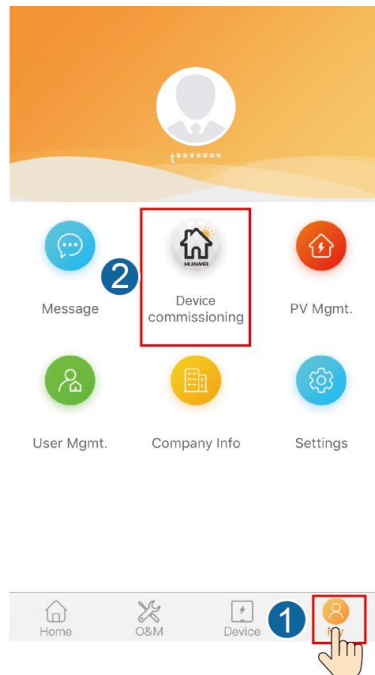
## 6.3.2 Scenario 2: Device Commissioning

1. Access **Device commissioning**.

**Figure 6-5** Method 1: before login



**Figure 6-6** Method 2: after login

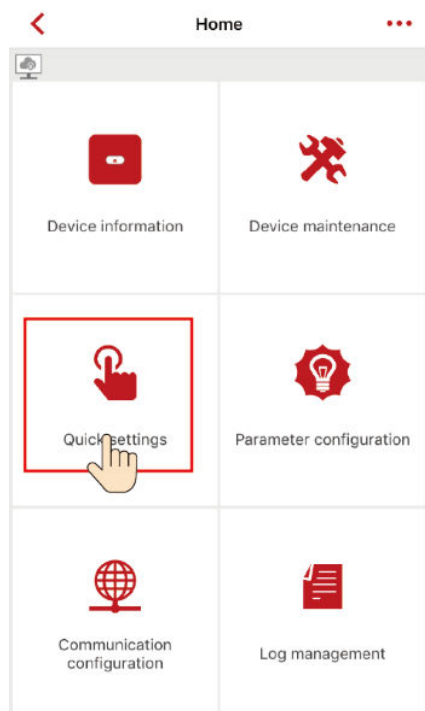


2. Connect to the inverter WiFi. Log in as **installer**, and perform **Quick settings**.

**NOTICE**

- When connecting the inverter to the app directly, keep the mobile phone visible within 3 meters of the inverter if the built-in antenna is used or within 50 meters of the inverter if the external antenna is used to ensure the communication quality between the app and inverter. The distances are for reference only and may vary with mobile phones and shielding conditions.
- When connecting the SUN2000L to the app over a router, ensure that the mobile phone and inverter are in the WiFi coverage of the router and the SUN2000L is connected to the router.
- The router supports WiFi (IEEE 802.11 b/g/n, 2.4 GHz) and the WiFi signal reaches the inverter.
- The WPA, WPA2, or WPA/WPA2 encryption mode is recommended for routers. Enterprise-level encryption is not supported (for example, public hotspots requiring authentication such as airport WiFi). WEP and WPA TKIP are not recommended because these two encryption modes have serious security defects.

**Figure 6-7** Quick settings



**NOTE**

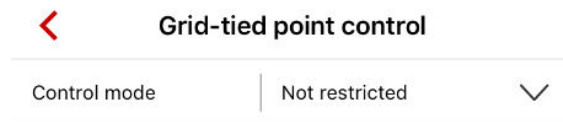
- The initial password for connecting the inverter WiFi is **Changeme**
- The initial password of the **installer** is **00000a**
- Use the initial password upon first power-on and change it immediately after login. To ensure account security, change the password periodically and keep the new password in mind. Not changing the initial password may cause password disclosure. A password left unchanged for a long period of time may be stolen or cracked. If a password is lost, devices cannot be accessed. In these cases, the user is liable for any loss caused to the PV plant.
- To set more parameters, tap **Parameter configuration**.

## 6.4 Grid-tied Point Control

### Procedure

- Step 1** On the **Home** screen, choose **Device maintenance > Energy control > Grid-tied point control** and perform the required operation.

**Figure 6-8** Grid-tied point control



**Table 6-3** Description of control mode parameters

Parameter	Description	Value Range
Control mode	<p>If this parameter is set to <b>Not restricted</b>, the SUN2000L output power is not limited. The SUN2000L can export its rated power to the power grid.</p> <p>If this parameter is set to <b>Grid connected with zero power</b> and the SUN2000L is connected to a power meter, the output power of the SUN2000L is supplied only to the local load, but not the power grid.</p> <p>If this parameter is set to <b>Power-limited Grid Connected</b> and the SUN2000L is connected to a power meter, the SUN2000L supplies power limited based on the setting of <b>Grid-tied Point Power</b> to the power grid.</p>	<ul style="list-style-type: none"> <li>• Not restricted</li> <li>• Grid connected with zero power</li> <li>• Power-limited Grid Connected</li> </ul>

----End

## 6.5 Powering Off the System

### Context



After the SUN2000 powers off, the remaining electricity and heat may still cause electric shocks and body burns. Therefore, put on protective gloves and begin servicing the SUN2000 five minutes after the power-off.

---

### Procedure

- Step 1** Send a shutdown command from the FusionHome app.
  - Step 2** Turn off the AC switch between the SUN2000 and the power grid.
  - Step 3** Turn off the DC switch at the bottom of the SUN2000.
  - Step 4** Turn off the DC switch between the PV string and the SUN2000 if there is any.
- End

# 7 System Maintenance

## 7.1 Routine Maintenance

To ensure that the SUN2000 can operate properly for a long term, you are advised to perform routine maintenance on it as described in this chapter.

**⚠ CAUTION**

Before cleaning the system, connecting cables, and maintaining the grounding reliability, power off the system (see [6.5 Powering Off the System](#) for details).

**Table 7-1** Maintenance list

Check Item	Acceptance Criteria	Maintenance Interval
System cleanliness	The heat sinks are free from obstacles or dust.	Once every 6 to 12 months
System running status	<ul style="list-style-type: none"><li>The SUN2000 is not damaged or deformed.</li><li>The SUN2000 operates with no abnormal sound.</li><li>All SUN2000 parameters are correctly set. Perform this check when the SUN2000 is running.</li></ul>	Once every 6 months
Electrical connections	<ul style="list-style-type: none"><li>Cables are securely connected.</li><li>Cables are intact, and in particular, the parts touching the metallic surface are not scratched.</li><li>Unused DC input terminals, COM ports, ANT ports, and USB-4G ports are locked by watertight caps.</li></ul>	The first maintenance is half a year after the initial commissioning. From then on, perform the maintenance once every 6 to 12 months.



Check Item	Acceptance Criteria	Maintenance Interval
Grounding reliability	Ground cables are securely connected.	The first maintenance is half a year after the initial commissioning. From then on, perform the maintenance once every 6 to 12 months.

## 7.2 Troubleshooting

Alarm severities are defined as follows:

- Major: The SUN2000 enters Shutdown mode and disconnects from the power grid to stop generating power after a fault occurs.
- Minor: Some components are faulty but the SUN2000 can still connect to the power grid and generate power.
- Warning: The SUN2000 output power decreases due to external factors.

**Table 7-2** Common alarms and troubleshooting measures

Alarm ID	Alarm Name	Alarm Severity	Possible Cause	Suggestion
2001	High String Input Voltage	Major	<p>The PV array is incorrectly configured. Excessive PV modules are connected in series to the PV string, and therefore the open-circuit voltage exceeds the maximum inverter input voltage.</p> <p>The following is the mapping between PV strings and alarm cause IDs:</p> <ul style="list-style-type: none"> <li>• Cause ID = 1: string 1</li> <li>• Cause ID = 2: string 2</li> </ul>	<p>Reduce the number of PV modules connected in series to the PV string until the PV string open-circuit voltage is less than or equal to the maximum inverter input voltage. After the PV array is correctly configured, the inverter alarm disappears.</p>
2011	String Reversed	Major	<p>The PV string is reversely connected.</p> <p>The following is the mapping between PV strings and alarm cause IDs:</p> <ul style="list-style-type: none"> <li>• Cause ID = 1: string 1</li> <li>• Cause ID = 2: string 2</li> </ul>	<p>Check whether the PV string is reversely connected to the SUN2000. If yes, wait until the PV string current reduces to below 0.5 A. Then, turn off the DC switch and correct the PV string polarity.</p>

Alarm ID	Alarm Name	Alarm Severity	Possible Cause	Suggestion
2012	String Current Backfeed	Warning	<p>Only a few PV modules are connected in series in the PV string. Therefore, the end voltage is lower than that of other PV strings.</p> <p>The following is the mapping between PV strings and alarm cause IDs:</p> <ul style="list-style-type: none"> <li>• Cause ID = 1: string 1</li> <li>• Cause ID = 2: string 2</li> </ul>	<ol style="list-style-type: none"> <li>1. Check whether the number of PV modules connected in series to this PV string is less than the number of PV modules connected in series to the other PV strings connected in parallel with this PV string. If yes, wait until the PV string current drops below 0.5 A, set <b>DC SWITCH</b> to <b>OFF</b>, and adjust the number of PV modules in the PV string.</li> <li>2. Check whether the PV string is shaded.</li> <li>3. Check whether the open-circuit voltage of the PV string is normal.</li> </ol>
2032	Grid Failure	Major	<p>Cause ID = 1</p> <ul style="list-style-type: none"> <li>• The power grid experiences an outage.</li> <li>• The AC circuit is disconnected or AC switch is off.</li> </ul>	<ol style="list-style-type: none"> <li>1. Check the AC voltage.</li> <li>2. Check that the AC power cable is connected and that the AC switch is ON.</li> </ol>
2033	Grid Undervoltage	Major	<p>Cause ID = 1</p> <p>The grid voltage is below the lower threshold or the low voltage duration has lasted for more than the value specified by LVRT.</p>	<ol style="list-style-type: none"> <li>1. If the alarm occurs accidentally, the power grid may be abnormal temporarily. The SUN2000 automatically recovers after detecting that the power grid becomes normal.</li> <li>2. If the alarm occurs frequently, check whether the grid voltage is within the acceptable range. If no, contact the local power operator. If yes, modify the power grid undervoltage protection thresholds with the consent of the local power operator.</li> <li>3. If the fault persists for a long time, check the connection between the AC switch and the output power cable.</li> </ol>

Alarm ID	Alarm Name	Alarm Severity	Possible Cause	Suggestion
2034	Grid Overvoltage	Major	<p>Cause ID = 1</p> <p>The grid voltage exceeds the higher threshold or the high voltage duration has lasted for more than the value specified by HVRT.</p>	<ol style="list-style-type: none"> <li>1. Check whether the grid connection voltage exceeds the upper threshold. If yes, contact the local power operator.</li> <li>2. If you have confirmed that the grid connection voltage exceeds the upper threshold and obtained the consent of the local power operator, modify the overvoltage protection thresholds.</li> <li>3. Check whether the peak grid voltage exceeds the upper threshold.</li> </ol>
2035	Unbalanced Grid Voltage	Major	<p>Cause ID = 1</p> <p>The difference between grid phase voltages exceeds the upper threshold.</p>	<ol style="list-style-type: none"> <li>1. Check that the grid voltage is within the normal range.</li> <li>2. Check the connection of the AC output power cable.</li> <li>3. If the cable connection is proper but the alarm occurs frequently and affects the power production of the PV plant, contact the local power operator.</li> </ol>
2036	Grid Overfrequency	Major	<p>Cause ID = 1</p> <p>Power grid exception: The actual grid frequency is higher than the local power grid standard.</p>	<ol style="list-style-type: none"> <li>1. If the alarm occurs accidentally, the power grid may be abnormal temporarily. The SUN2000 automatically recovers after detecting that the power grid becomes normal.</li> <li>2. If the alarm occurs frequently, check whether the grid frequency is within the acceptable range. If no, contact the local power operator. If yes, modify the grid overfrequency protection threshold with the consent of the local power operator.</li> </ol>
2037	Grid Underfrequency	Major	<p>Cause ID = 1</p> <p>Power grid exception: The actual grid frequency is lower than the local power grid standard.</p>	<ol style="list-style-type: none"> <li>1. If the alarm occurs accidentally, the power grid may be abnormal temporarily. The SUN2000 automatically recovers after detecting that the power grid becomes normal.</li> <li>2. If the alarm occurs frequently, check whether the grid frequency is within the acceptable range. If no, contact the local power operator. If yes, modify the grid underfrequency protection threshold with the consent of the local power operator.</li> </ol>

Alarm ID	Alarm Name	Alarm Severity	Possible Cause	Suggestion
2038	Unstable Grid Frequency	Major	Cause ID = 1 Power grid exception: The actual grid frequency change rate does not comply with the local power grid standard.	<ol style="list-style-type: none"> <li>1. If the alarm occurs accidentally, the power grid may be abnormal temporarily. The SUN2000 automatically recovers after detecting that the power grid becomes normal.</li> <li>2. If the alarm occurs frequently, check whether the grid frequency is within the acceptable range. If no, contact the local power operator.</li> </ol>
2039	Output Overcurrent	Major	Cause ID = 1 The grid voltage drops dramatically or the power grid is short-circuited. As a result, the inverter transient output current exceeds the upper threshold and therefore the inverter protection is triggered.	<ol style="list-style-type: none"> <li>1. The SUN2000 monitors its external working conditions in real time. The SUN2000 automatically recovers after the fault is rectified.</li> <li>2. If the alarm occurs frequently and affects the power production of the PV plant, check whether the output is short-circuited. If the fault persists, contact your dealer.</li> </ol>
2040	Output DC Component Overhigh	Major	Cause ID = 1 The DC component of the SUN2000 output current exceeds the specified upper threshold.	<ol style="list-style-type: none"> <li>1. The SUN2000 monitors its external working conditions in real time. The SUN2000 automatically recovers after the fault is rectified.</li> <li>2. If the alarm occurs frequently, contact your dealer.</li> </ol>
2051	Abnormal Residual Current	Major	Cause ID = 1 The insulation impedance of the input side to PE decreases when the SUN2000 is operating.	<ol style="list-style-type: none"> <li>1. If the alarm occurs accidentally, the external power cable may be abnormal temporarily. The SUN2000 automatically recovers after the fault is rectified.</li> <li>2. If the alarm occurs frequently or persists, check that the impedance between the PV string and ground is not below the lower threshold.</li> </ol>

Alarm ID	Alarm Name	Alarm Severity	Possible Cause	Suggestion
2061	Abnormal Grounding	Major	Cause ID = 1 <ul style="list-style-type: none"> <li>The protective earthing (PE) cable for the SUN2000 is not connected.</li> <li>The voltage between the SUN2000 neutral wire and ground exceeds the upper threshold.</li> </ul>	<ol style="list-style-type: none"> <li>Check that the PE cable for the SUN2000 is connected properly.</li> <li>If the SUN2000 is connected to the TN power grid, check whether the voltage of the neutral wire to ground is normal.</li> <li>Check whether the output is connected to an isolation transformer. If so, set <b>Grounding inspection to Disable</b>.</li> </ol>
2062	Low Insulation Resistance	Major	Cause ID = 1 <ul style="list-style-type: none"> <li>The PV string is short-circuited to PE.</li> <li>The PV string is installed in a moist environment for a long time.</li> </ul>	<ol style="list-style-type: none"> <li>Check the impedance between the PV array output and PE, and eliminate short circuits and poor insulation points.</li> <li>Check that the SUN2000 PE cable is correctly connected.</li> <li>If you are sure that the impedance is less than the default value in a cloudy or rainy environment, reset <b>Insulation resistance protection</b>.</li> </ol>
2063	Overtemperature	Major	Cause ID = 1 <ul style="list-style-type: none"> <li>The SUN2000 is installed in a place with poor ventilation.</li> <li>The ambient temperature exceeds the upper threshold.</li> <li>The SUN2000 is not working properly.</li> </ul>	<ul style="list-style-type: none"> <li>Check the ventilation and ambient temperature at the SUN2000 installation position.</li> <li>If the ventilation is poor or the ambient temperature exceeds the upper threshold, improve the ventilation and heat dissipation.</li> <li>If the ventilation and ambient temperature both meet requirements, contact your dealer.</li> </ul>
2064	Device Fault	Major	Cause ID = 1-12 An unrecoverable fault occurs on a circuit inside the SUN2000.	Turn off the AC output switch and DC input switch, and then turn them on after 5 minutes. If the fault persists, contact your dealer. Note: If the cause ID is ID 1, perform the preceding operation when the PV string current is less than 1 A.
2065	Upgrade Failed or Software Version Unmatch	Minor	Cause ID = 1-4 The upgrade does not end normally.	<ol style="list-style-type: none"> <li>Perform an upgrade again.</li> <li>If the upgrade fails several times, contact your dealer.</li> </ol>

Alarm ID	Alarm Name	Alarm Severity	Possible Cause	Suggestion
61440	Monitoring Unit Faulty	Minor	Cause ID = 1 <ul style="list-style-type: none"><li>The flash memory is insufficient.</li><li>The flash memory has bad sectors.</li></ul>	Contact your dealer to rectify the fault.
2067	Faulty Power Collector	Major	Cause ID = 1 The power meter communication is interrupted.	<ol style="list-style-type: none"><li>Check that the preset power collector model is the same as the actual model.</li><li>Check that the preset communications parameters for the power collector are the same as the actual configurations.</li><li>Check that the power collector is powered on and the RS485 communications cable is correctly connected.</li></ol>



**NOTE**

Contact your dealer if all failure analysis procedures listed above are completed and the fault still exists.

# 8 Handling the SUN2000

---

## 8.1 Removing the SUN2000

### Procedure

- Step 1** Power off the system by following the instructions in [6.5 Powering Off the System](#).
  - Step 2** Disconnect all cables from the SUN2000, including signal cables, DC input power cables, AC output power cables, and PE cables.
  - Step 3** Remove the WiFi antenna or 4G Smart Dongle from the SUN2000.
  - Step 4** Remove the SUN2000 from the mounting bracket.
  - Step 5** Remove the mounting bracket.
- End

## 8.2 Packing the SUN2000

- If the original packaging is available, put the SUN2000 inside it and then seal it using adhesive tape.
- If the original packaging is not available, put the SUN2000 inside a suitable cardboard box and seal it properly.

## 8.3 Disposing of the SUN2000

If the SUN2000 service life expires, dispose of it according to the local disposal rules for electrical equipment and electronic component waste.

# 9 Technical Specifications

## Efficiency

Item	SUN2000-2KT L-L0	SUN2000-3KT L-L0	SUN2000-4KT L-L0	SUN2000-5KT L-L0
Maximum efficiency	98.5%	98.5%	98.5%	98.5%
European weighted efficiency	97%	97.6%	97.9%	98%

## Input

Item	SUN2000-2KT L-L0	SUN2000-3KT L-L0	SUN2000-4KT L-L0	SUN2000-5KT L-L0
Maximum input voltage <sup>a</sup>	600 V			
Maximum input current (per MPPT)	11 A			
Maximum short-circuit current (per MPPT)	15 A			
Maximum inverter backfeed current to the PV array	0 A			
Minimum startup voltage	120 V			



Item	SUN2000-2KT L-L0	SUN2000-3KT L-L0	SUN2000-4KT L-L0	SUN2000-5KT L-L0
MPPT voltage range	90–500 V			
*/85	120–480 V	160–480 V	210–480 V	260–480 V
Rated input voltage	380 V			
Number of inputs	2			
Number of MPP trackers	2			
Note a: The maximum input voltage in Mexico is 500 V.				

## Output

Item	SUN2000-2KT L-L0	SUN2000-3KT L-L0	SUN2000-4KT L-L0	SUN2000-5KT L-L0
Rated output power	2 kW	3 kW	4 kW	5 kW
Maximum apparent power	2.2 kVA	3.3 kVA	4.4 kVA	5.5 kVA
Rated output voltage	220 V AC/230 V AC/240 V AC			
Adapted grid frequency	50/60 Hz			
Maximum output current	10 A	15 A	20 A	25 A
Power factor	0.8 leading... 0.8 lagging			
Maximum total harmonic distortion (rated power)	≤ 3%			

## Protection

Item	SUN2000-2KT L-L0	SUN2000-3KT L-L0	SUN2000-4K TL-L0	SUN2000-5K TL-L0
Anti-islanding protection	Supported			

Item	SUN2000-2KT L-L0	SUN2000-3KT L-L0	SUN2000-4K TL-L0	SUN2000-5K TL-L0
Input reverse polarity protection	Supported			
Output short-circuit protection	Supported			
RCMU	Supported			
AC surge protection	Supported			
DC surge protection	Supported			
Output overvoltage protection	Supported			
Insulation resistance detection	Supported			

## Communication

Item	SUN2000-2KT L-L0	SUN2000-3KT L-L0	SUN2000-4KT L-L0	SUN2000-5KT L-L0
Display	LED			
WiFi	Supported			
RS485	Supported			
4G	Optional			

## Common parameters

Item	SUN2000-2KT L-L0	SUN2000-3KT L-L0	SUN2000-4KT L-L0	SUN2000-5KT L-L0
Topology	Transformerless			
Ingress Protection Rating	IP65			
Cooling mode	Natural cooling			

Item	SUN2000-2KT L-L0	SUN2000-3KT L-L0	SUN2000-4KT L-L0	SUN2000-5KT L-L0
Dimensions (W x H x D)	375 mm x 375 mm x 117 mm (excluding the mounting plate)/375 mm x 375 mm x 149.5 mm (including the mounting plate)/440 mm x 440mm x 231mm (including the package)			
Weight	10.6kg (excluding the mounting plate)/13.2kg (including the package)			
Operating temperature	-30°C to +60°C (derated above +45°C)			
Humidity	0%–100% RH			
Operating altitude	0–4000 m (derated above 2000 m)			

# A Grid Codes

 **NOTE**

Grid codes are subject to change. The listed codes are for your reference only.

Grid codes (SUN2000-2KTL/3KTL/4KTL/5KTL-L0)

No.	Grid Code	Description	Grid Voltage	Grid Frequency
1	EN50438-NL	Netherlands	230 V	50 Hz
2.	C10/11	Belgium	230 V	50 Hz
3	TAI-PEA	Thailand	220 V	50 Hz
4	TAI-MEA	Thailand	230 V	50 Hz
5	EN50438-TR	Turkey	230 V	50 Hz
6	IEC61727-60Hz	IEC61727 low-voltage power grid (60 Hz)	230 V	60 Hz

# B Acronyms and Abbreviations

---

## A

**AC** alternating current

## D

**DC** direct current

## I

**ID** identifier

## L

**LED** light emitting diode

**LVRT** low voltage ride-through

## M

**MAC** Media Access Control

**MPPT** maximum power point tracking

## P

**PC** personal computer

**PE** protective earthing

**PV** photovoltaic

## R

**RCMU** residual current monitoring unit

<b>RH</b>	relative humidity
<b>S</b>	
<b>SN</b>	serial number
<b>T</b>	
<b>THDi</b>	total distortion of the input current waveform
<b>W</b>	
<b>WEEE</b>	waste electrical and electronic equipment
<b>WiFi</b>	Wireless Fidelity